

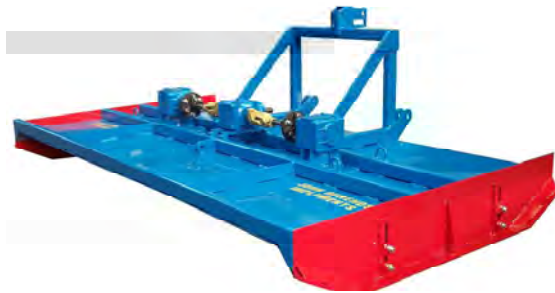

# John Berends Implements Pty Ltd

AGRICULTURAL ENGINEERS

## OPERATOR'S MANUAL PARTS LIST



### Pasture Topper

**PRODUCT NO.**

0115	3.0m (10') 3 Point Linkage Pasture Topper – 45 HP
0016	3.0m (10') 3 Point Linkage Pasture Topper – 75HP
0117	Wheel Kit to suit 3.0m (10') Pasture Topper - 2 Holden Castor Wheels

130 FRANKSTON/DANDENONG RD, DANDENONG SOUTH, VIC. 3175 AUSTRALIA

PHONE (03) 9791 2494

FAX NO. (03) 9794 5568

[www.johnberendsimplements.com.au](http://www.johnberendsimplements.com.au)

**INTRODUCTION:**

This manual was developed specifically for the machine you have purchased. The information within is to assist you in preparing, operating and maintaining your machine. Please read and understand the contents of the manual completely before attempting to operate your machine, paying special attention to all safety details. With our policy of continuous improvement, products and specifications may change without notice and without incurring the obligation to install such changes on any unit previously delivered.

**Pasture Toppers**

Three point linkage pasture toppers are available in 10' widths only. Optional wheel-kits fitted with 14" Holden wheels and adjusted by a ratchet link (or optional hydraulics) are also available. The top plate is 3mm thick and the adjustable skids are 6mm thick. There are two outer gearboxes driven by a centre T gearbox. There is a rubber coupling flex-drive set-up with shear-bolt protection between each box. The blades are timed and deeply stepped and twisted to help lift pasture prior to cutting. The series 5 PTO shaft is fitted with a 4 plate slip clutch.

**MACHINE SPECIFICATIONS**

<b>Pasture Topper</b>	<b>10'- Three Point Linkage</b>
Cutting width	2.90m
Cutting height (with adj skids)	25-100mm
Weight	500kg
Length (Overall)	1.85m
Width (Overall)	3.12m
Headstock	Rigid/floating top link
Body construction	3mm body, 6mm sides
Tractor HP range	35HP+
PTO	Series 5 shaft with 2 plate slip clutch
Gearbox/PTO speed	540 rpm
Centre Gearbox	75 HP
End Gearboxes	45HP or 75HP (optional)
Gearbox Protection	Flexible couplings with shearbolt protection
Tractor Cat connection	Cat 1 / 2

**WARRANTY**

John Berends Implements P/L warrants each new product sold to be free from defects in material and workmanship, under normal use and service, as outlined in the operators manual, for a period of 12 months.

This warranty is void if any damage to the machine has been caused by misuse or non genuine parts have been used or any repairs have been made by any persons other than authorised dealer service personnel.

The manufacturer/dealer is not obligated to any transportation charges incurred in the repair or replacement of parts.

This warranty does not exclude any condition or warranty implied by the Trade Practices Act 1974 or any other legislation which implies any condition which cannot be excluded.

© Copyright 1998

This Safety Manual is copyright and no part may be reproduced without the written permission of John Berends Implements.

## TABLE OF CONTENTS

**Page No.**

TROUBLE SHOOTING.....	1
SAFETY INSTRUCTIONS.....	2
SAFETY FEATURES.....	4
ASSEMBLY.....	5
OPERATION.....	5
MAINTENANCE.....	6
SPARE PARTS.....	9

### Trouble Shooting

<u>Defect</u>	<u>Component</u>	<u>Possible Cause</u>
Vibration	P.T.O shaft	Twisted/bent shaft Universal joints damaged or worn Lifting topper too high while P.T.O. engaged
	Rotor and blades	Damaged due to obstruction by foreign object Blades not loose on bushes
Excessive noise	Gearbox	Worn or loose bearing No oil
	P.T.O. shaft	Lifting topper too high while P.T.O. engaged
Leaking oil	Gearbox	Loose/damaged seals and/or bearings
Not cutting grass	Rotor	Rubber blocks in flexible coupling are damaged. Shear-bolts have broken
Excessive heat	Slip Clutch	Worn friction discs Incorrect spring adjustments Incorrect positioning of pressure plate
	P.T.O. shaft	Needs lubrication





# SAFETY





Farm machinery is dangerous if operated incorrectly so please read this manual in its entirety prior to operating the machine.

 No operator, however experienced in farm machinery operation, should attempt to use any machine they have not been competently trained to use. Your local Department of Agriculture can help you with training, as can most Occupational Health and Safety offices, Agricultural schools and colleges and farm equipment dealerships.

 All instructions relating to tractor safety as per the tractor operators manual should be followed. When making any machine adjustments, stop the tractor engine first and wait for all moving parts to stop. Maintain the tractor to ensure it remains safe to use. Do not operate faulty or damaged equipment.

 Extreme caution should be taken when fitting equipment to the tractor's three point linkage. Avoid standing between the implement and the tractor when coupling machinery.

 All machines should be mounted and retained correctly. All guards must be kept in place and correctly maintained. P.T.O. shafts must be correctly attached and secured to both the tractor and the machine. Decals must be visible and legible at all times. Keep well clear of all moving parts.

 Keep all people and animals at a safe distance from all moving parts. Children must not be allowed to operate this equipment and all passengers must have the same level of protection as the operator.

 Wear protective clothing where appropriate.

 Never operate when tired (not alert) or in poorly lit areas and stay alert for humps and other hidden hazards. Remove all timber, rocks and foreign objects prior to operation.

 Avoid operating the machine in wet conditions.

 Exercise extreme caution when changing direction on hills. Avoid sudden movement, sudden breaking, high speeds, rough terrain and steep slopes.

 If machine starts to vibrate, stop tractor using method as described in the operation section (Page 8)

 After striking a foreign object or if there are doubts about the performance of the machine, stop the tractor as described and check if machine is making excessive noise.

 Extreme caution must be taken when working in public areas (roadsides etc). It is recommended that flaps and chains are fitted in these areas. These are available as optional extras. Rear flaps are compulsory in public areas.

 Do not modify this equipment in anyway, or use it for any other purpose than it was designed to do.

 Never work under unsupported machines or adjust unsupported machines. Do not enter the danger zone where a load being carried by a machine could fall on you, for example a round bale from a bale fork, a log from a carryall or material from a rear end loader.

These instructions should be used in conjunction with any local regulations regarding safety ie OHS.

Maintenance is essential for safe operation. Ensure maintenance is carried out regularly by people qualified to do so. This is of particular importance on P.T.O. drive machines where driven parts can fly off at high speed if wearing parts are not properly maintained.

**FAILURE TO FOLLOW THESE INSTRUCTIONS AND PROCEDURES MAY RESULT IN EQUIPMENT MALFUNCTION, OR DAMAGE, SERIOUS INJURY OR EVEN DEATH.**

## Safety Features

1. MODEL NUMBER
2. SERIAL NUMBER (Decal)
3. WARNING DECAL
4. CAUTION DECAL FOR P.T.O. SHAFT
5. BERENDS DECAL
6. FLEXIBLE COUPLING COVER GUARD
7. P.T.O. SHAFT INNER/OUTER GUARDS
8. CLUTCH COVER

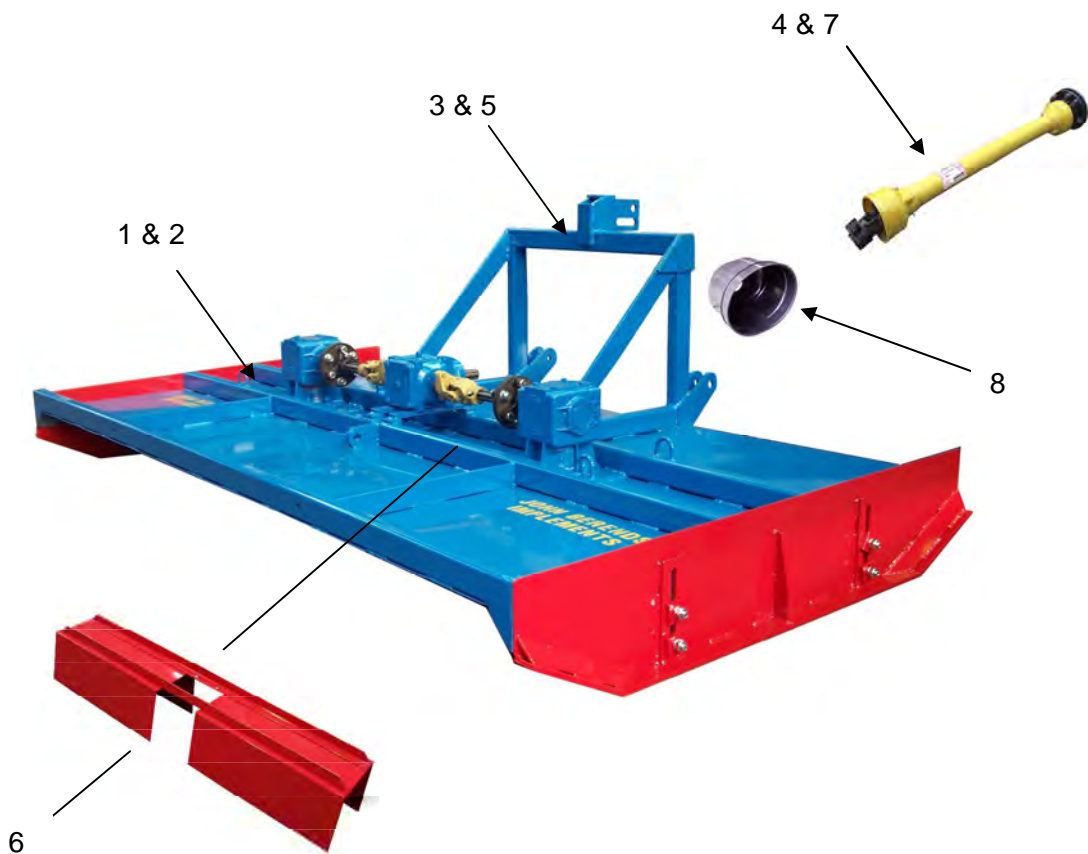

## **ASSEMBLY**

Line up the lower linkage arms with the linkage pins of the topper, slide the linkage arms onto the pins and secure with linch pins. Attach the top link to the topper. Raise the topper from the ground and adjust stabiliser bars or chains if required.

Care must be taken when operating on tractors with down pressure, as this prevents the topper from floating when hitting obstructions.

### **CAUTION:**

Check the length of the P.T.O. shaft before connecting to the tractor by raising the shaft to a position where it would be horizontal when connected. If necessary have the shaft shortened by cutting the same amount off both metal tubes and both plastic covers (Refer to P.T.O shaft section p.10). This can be done with a hacksaw.

## **FITTING AND REMOVAL OF P.T.O. SHAFT**

The clutch end of the P.T.O. shaft is located in the groove on the topper input shaft with a quick release pin. This is similar to the quick release pin on the tractor end. The P.T.O. shaft can be fitted or removed by depressing the pin. To avoid difficulties later it is advisable to apply some grease to the input shaft prior to fitting the P.T.O. shaft.

## **OPERATION**

Once all safety procedures have been followed, start the tractor and raise the topper approximately 100-200mm (4-6 inches) off the ground.

Depending on the tractor it may be possible to lift the topper too high and the P.T.O. shaft may hit the topper body. Set the adjustment on your hydraulics before operation, do not depend on your memory. Engage P.T.O. drive and put the tractor into gear. Build up revolutions to 540 rpm and edge slowly forward while lowering the topper. To minimise wear and tear on both tractor and topper the P.T.O. speed should be maintained at 540 rpm. Lower speeds cause excessive wear, especially to blades and blade bolts, as the blades move continuously due to low centrifugal force. If the operator is not certain of the condition of the area to be topped, a prior inspection is recommended. Remove all timber, rocks and foreign objects. All machines are fitted with a flexible rubber coupling system plus additional shear-bolt protection between the gearboxes.

### **CAUTION:**

**The pasture topper is designed for topping only, for slashing work a topper should be used. Do not hit rocks, stumps or foreign objects. Do not scalp the ground. Any damage caused by misuse is void of warranty.**

### **CAUTION:**

Always allow for the effect the weight of the topper has on the performance of the tractor, particularly on sloping hillsides and unstable areas. If working in undulating conditions the toggle link enables the topper to lift at the rear without lifting the front

## **STOPPING**

Slow engine speed to idle and disengage P.T.O shaft. Lower the machine, stop the tractor engine (removing the ignition key) and apply the park brake. Remain clear until the machine has stopped its rotation completely.

## **HEIGHT ADJUSTMENT**

### **1) Adjustable skids**

Loosen off the nuts sufficiently for the skids to be moved up or down. It is an advantage if the front of the topper is about 20-30mm lower than the rear. Note: Slots in the skids are provided instead of holes so as to enable the topper to be tilted forward, while the whole skid remains in contact with the ground.

### **2) Wheel kits**

All pasture toppers have an optional wheelkit for height adjustment. To adjust these wheels, the operator must disengage the P.T.O. and manually adjust the ratchet until the required height is obtained. In the case where hydraulics have been fitted as an option, the wheelkit can be adjusted from the tractor seat.

## **MAINTENANCE**

When doing any type of maintenance on this machine, always follow the safety steps described in this manual. Service should only be carried out by qualified personnel. Use only authorised genuine parts for replacement.

The topper must be adequately supported under its body on all twin rotor machines (Make certain it cannot fall). After 1-2 hours work, check all bolts and nuts and tighten if necessary. Check all fasteners and guards are installed (Refer to page 4)

### **Gearbox**

It is recommended the first oil change occur after 50 working hours; subsequent changes should take place after 500-800 working hours. Periodically check the oil level and top up with HD140 gearbox oil if necessary. Regularly check for leaks by lifting the topper, turning off the engine and looking underneath the topper for any oil.

### **Blades**

Check topper bolts and blades every 8 working hours. Check the blades are not jammed, are sharp and evenly worn and are free of nicks and cracks. If too much movement is apparent, replace the bolts and bushes (if fitted). When replacing blades, make sure they are fitted correctly. If the blades hit each other at any time it means that the blades are incorrectly timed. The timing is controlled by the flexi-drive system between the gearboxes (refer flexi-drive system section)

### **Rotor**



Remove any foreign material wrapped around the rotor.

### **Flexible rubber couplings**

There are flexible rubber couplings fitted between each gearbox which absorb small shock loads on the rotor. Over time these couplings may wear and require replacing. Check these regularly for excessive movement.

### **Torque limiting yoke**

In addition to the flexible coupling there are torque limiting yokes fitted between each gearbox. These are similar to a regular yoke but are fitted with a shearbolt set at a pre-determined torque. This provides additional protection should the topper be used in conditions it isn't designed for.

### **Wheel kit**

Check tyre pressure. Wheel must run freely on axle and yoke must be lubricated. Note: Bearings are replaceable if necessary.

### **Hydraulic Fittings and Hoses (where applicable)**

Before doing any maintenance on the hydraulic system, release the oil pressure. Be careful when searching for oil leaks as oil escaping under pressure can be invisible and may penetrate the skin.

### **Power take off (p.t.o.) shaft**

Before operating the machine, check that the P.T.O. shaft is securely attached to the tractor and to the topper.

Confirm the minimum and maximum working lengths of the P.T.O. shaft. The telescopic tubes must be overlapping at least 150mm. If it is necessary to shorten the shaft, contact your implement dealer.

Check that the tube guards are not damaged and rotate freely on the P.T.O. shaft. Safety chains must be sufficiently loose to allow free turning of the tube guards.

Check that the angle of the joints on the P.T.O. shaft do not exceed 35 degrees.

When machine is not in use, protect or cover the P.T.O. shaft from the weather.

Check all components are fully lubricated before use. Frequently grease all points as shown in Figure 2.

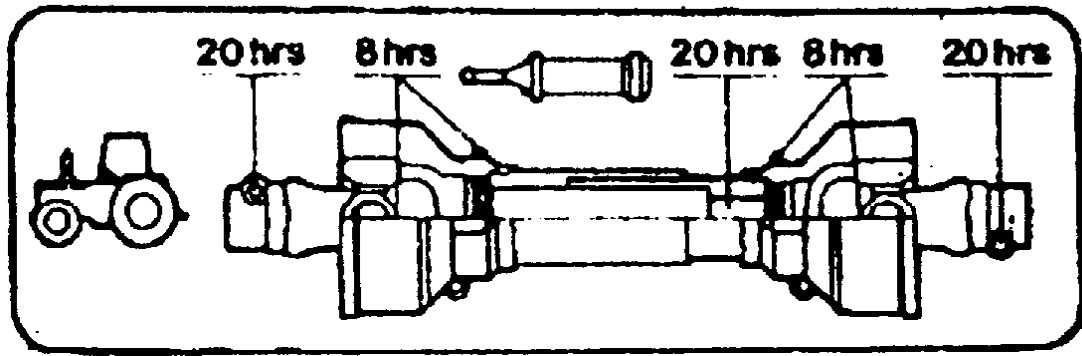

**FIGURE 2. :** Grease points and intervals for P.T.O. shaft.

### Slip clutch setting

#### **Slip Clutches need to be set if one of the following occurs:**

- The clutch has been repaired (including replacing the friction discs).
- The clutch is slipping in work (clutch getting hot, burning out friction discs, machine slowing down in work).
- The clutch is not slipping when the machine hits an obstruction (tractor stalls, P.T.O. breaks).
- The clutch has been freed up after a period of storage (see "how to free up clutch" next page).

#### **How to set the clutch**

The setting of the clutch is dependent on many variables - the work, the size of the tractor, the size of the machine and so on. It is best to set each clutch individually if possible. The aim is to start with a loose clutch and tighten it up to the exact point where it stops slipping in normal work. If set in this way the clutch will slip if any load exceeds this point, protecting both tractor and machine. It is best to set up the clutch with the machine on the tractor which will normally be used, and in conditions which approximate to the normal work the machine does.

These friction clutches are equipped with special Belleville springs, designed to apply pressure that varies with the amount of compression. The compression of the Belleville springs must be adjusted to compensate for wear of the friction linings and to maintain the desired setting.

Do not over-tighten the bolts. This may endanger the function of the clutch. The table below set out spring codes, thicknesses and compression 'h' measured as shown in the figure for standard settings. The height of the spring is measured next to each bolt and may be  $\pm 0.2\text{mm}$  of the listed value. The tables also show the amount of rotation of each bolt required to achieve the next higher or lower setting, relative to the nominal setting (listed with no rotation noted on the bolt). In addition to the listed settings, intermediate settings may be obtained by tightening or loosening the bolts proportionately.

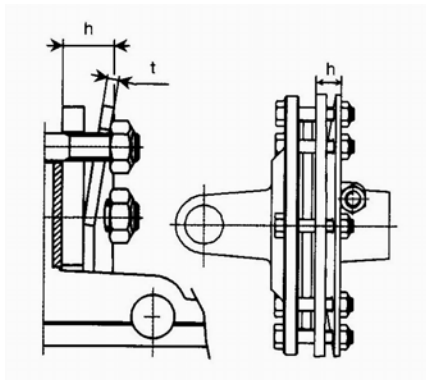

FV22 Friction clutches			
2 plates, diameter 155 mm			
Spring code	t mm	Setting Nm	h mm
367005850	3.75	400	13.5
		600	13.0
		800	12.5

The clutch must be quite loose initially to ensure it will slip. Slipping can be identified by the clutch getting very hot. The clutch will always be quite warm in work as the gearbox gets warm. Run the machine for a short distance (20 metres) in work and check the clutch slips. Then tighten each tension bolt up a turn (more if the clutch was very loose) evenly and run a short distance again. Keep repeating this procedure until the clutch is not slipping - it should only take a few stops. As you get to the point at which the clutch is not slipping tighten the tension bolts half a turn instead of a full turn.

If the clutch still slips when you have set the maximum recommended setting, *reduce the load*. Reduce your ground-speed or take less cut. Otherwise you risk damaging the machine. *Whenever a slip clutch slips take all load off it until full operating speed is regained with zero load. Continuing operations with a slipping clutch results in clutch damage.*

Continue to work the machine checking the clutch regularly to see how it is performing. You may want to adjust it for varying conditions. If the clutch is too loose it will slip, wearing out the friction discs, getting hot and possibly damaging the clutch pressure surfaces as well. Remember as the plates wear, the tension on them is reduced. If the clutch is too tight it will fail to protect the tractor and machine when an overload occurs.

#### **How to free up the clutch after a period of storage**

Slip clutches can seize up if left for long periods without use. To free up the clutch loosen all the tension bolts until the Belleville spring is free of any tension. Then run the machine into normal work so the clutch slips. With the clutch set in this way the machine will fail to work at all, clutch slip being 100%. Run the machine in this way for 30 seconds to one minute. This cleans the surfaces of the clutch. An alternative to this is dismantling the clutch and cleaning it.

## **SPARE PARTS**

ORDER SPARE PARTS THROUGH YOUR ORIGINAL SUPPLIER OR YOUR LOCAL JOHN BERENDS IMPLEMENTS DEALER.

Always quote the machine serial No. or product No., spare part number and its part name as stated in the operator's manual.

#### **Glossary of terms**

c/w = Complete with

sw = Spring Washer

n.s.s. = Not serviced separately

a.r. = As required

fw = Flat Washer

**10' Pasture Topper- (0115/0116)**

Key No	Part No	Quantity	Description
1		1	Topper Body (priced on request)
	3214	1	Floating top link bracket (pre 2004)
	3215	1	Bolt suit floating top link (pre 2004)
2	1971	1	Cat 1/2 Single Step P/Through Linkage Pin
3	1588	2	Gearbox – 40HP model (re: gearbox section)
	1590	2	Gearbox – 75HP model (re: gearbox section)
4	3710	2	Flexible couplings –outer gearbox end
	3737	2	Rubber plate suit above
5	3738	2	Splined Shaft between G/boxes
6	3691	2	Topper shear-bolt yoke uni yoke coupling (refer next page for breakdown)
7	1895	1	Gearbox (for breakdown re: gearbox section)
8	3199	1	Safety cover
9	3200	4	Bolt & washer assembly suit above
10	3029	1	P.T.O. (refer to pto section)
11	3739	4	Gearbox mount bolt/sw
12	3740	1	Gearbox cover
13	3741	4	Gearbox cover mounting bolt/sw
14	3742	8	Gearbox mount bolt/nut sw
15	3743	2	Adjustable skids 10' topper
	3744	2	Runners suit above
16	3745	4	Adj skid bolt c/w plate/nut/sw
17	3746	2	Deflector guards - front
18	3747	4	Bolts/nuts/sw suit deflector guards

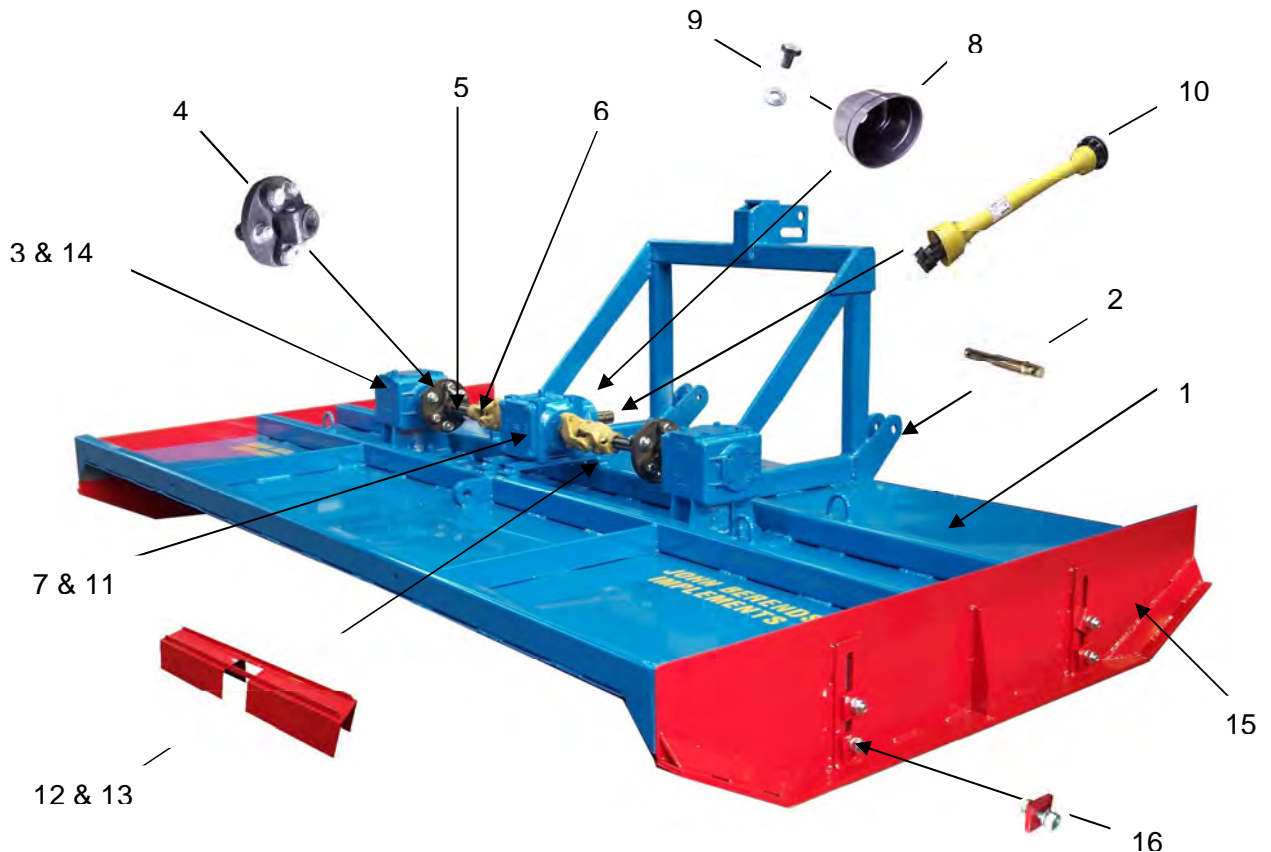

### Topper Shear Bolt Torque Limiter

Key No	Part No	Quantity	Description
1	3695	1	Grease Nipple
2	3696	1	Ball
3	3697	1	Shearbolt
4	3688	1	Yoke
5	3689	1	Hub with push pin
6	3690	1	Push pin kit
	3691	1	Complete Shearbolt Torque Limiter

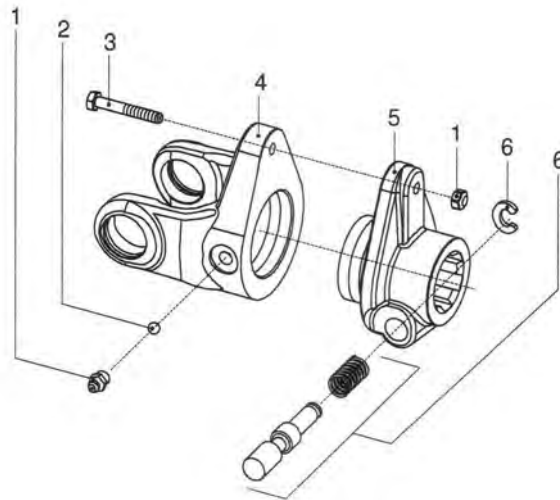

### Pasture topper

The topper has a unique blade beam assy. Rotors are fitted with either a pair of right hand or a pair of left hand blades. Blade bolt nut and bush have a retaining washer. This retainer does not normally have to be replaced unless damaged.

Key No.	Part No.	Quantity	Description
1	1800	2	Topper blade R/H
	1801	2	Topper blade L/H
2	1823	4	Bolt/nut/bush
3	1824	4	Topper blade retaining washer
4	1583	2	Rotor Beam
5	3934	1	Topper hub/boss complete with bolts



### 10' Topper wheel kit (0117)

Key No	Part No	Quantity	Description
1	3799	2	Single wheel yoke & sleeve
2	1804	2	Axle (inc. studs/nuts)
3	3247	2	Tyre
	3248	2	Rim
4	1927	4	Wheel bearing
5	1965	4	Bearing housing
6	3800	8	Bolt/nut/sw suit bearing housing
7	3801	8	Bolt/nut/sw suit main frame
8		1	Main Frame
9	3234	6	Grease nipple
10	3235	2	Bolt & nut suit sleeve

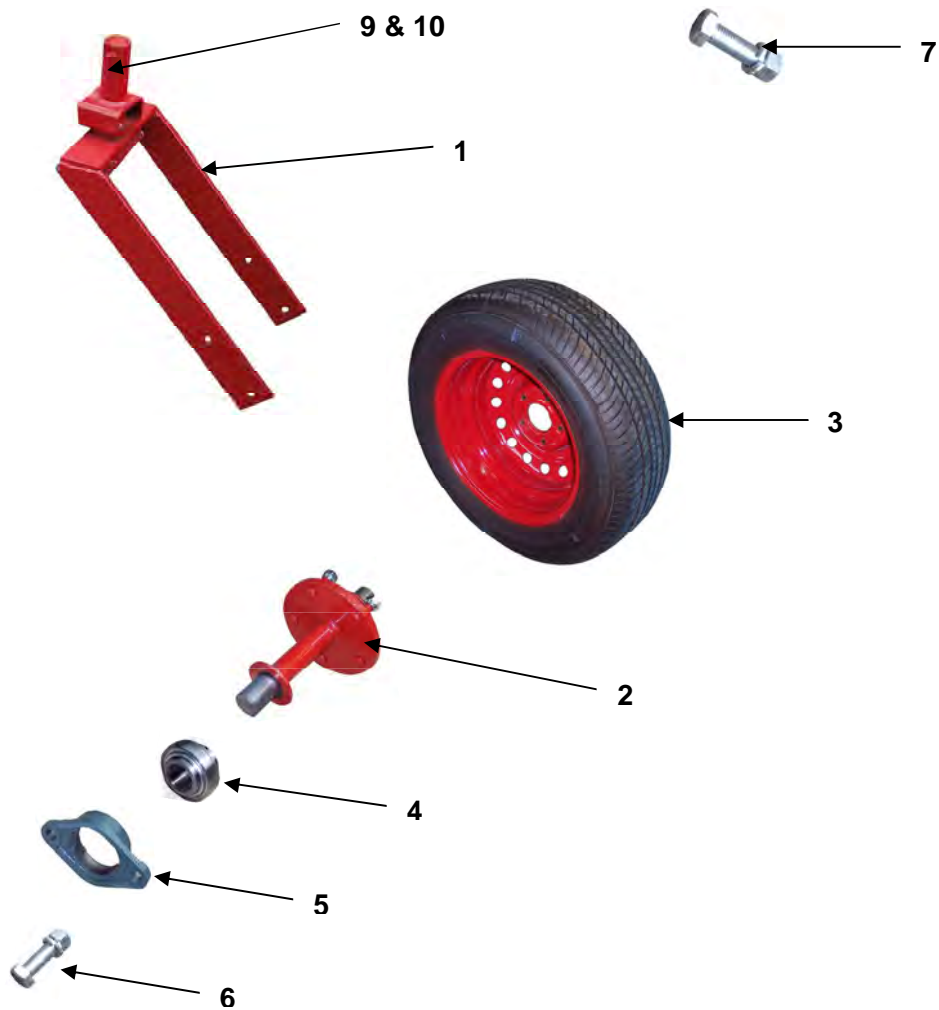

### Topper– shaft with plate tensioned clutch

Key no.	Part no.	Quantity	Description
1	3061	1	Yoke
2	3062	2	Cross/universal joint
3		8	Circlip - n.s.s.
4		2	Grease nipple – n.s.s.
5	3063	1	Outer tube yoke
8	3025	1	Roll pin
12	3064	1	Outer drive tube
13	3065	1	Inner drive tube
16	3026	1	Roll pin
17	3066	1	Inner tube yoke
21	3069	1	Clutch
26	3082	1	Outer shield support
32	3082	1	Inner shield support
40		1	Chain
48		1	Danger label
49		1	Danger decal
50		1	Instruction booklet
51	3067	1	Quick release pin
97	3080	1	Inner cover
97	3081	1	Outer cover
	3029	1	Complete shaft c/w clutch
	3897	1	Complete shaft c/w clutch suit HD200

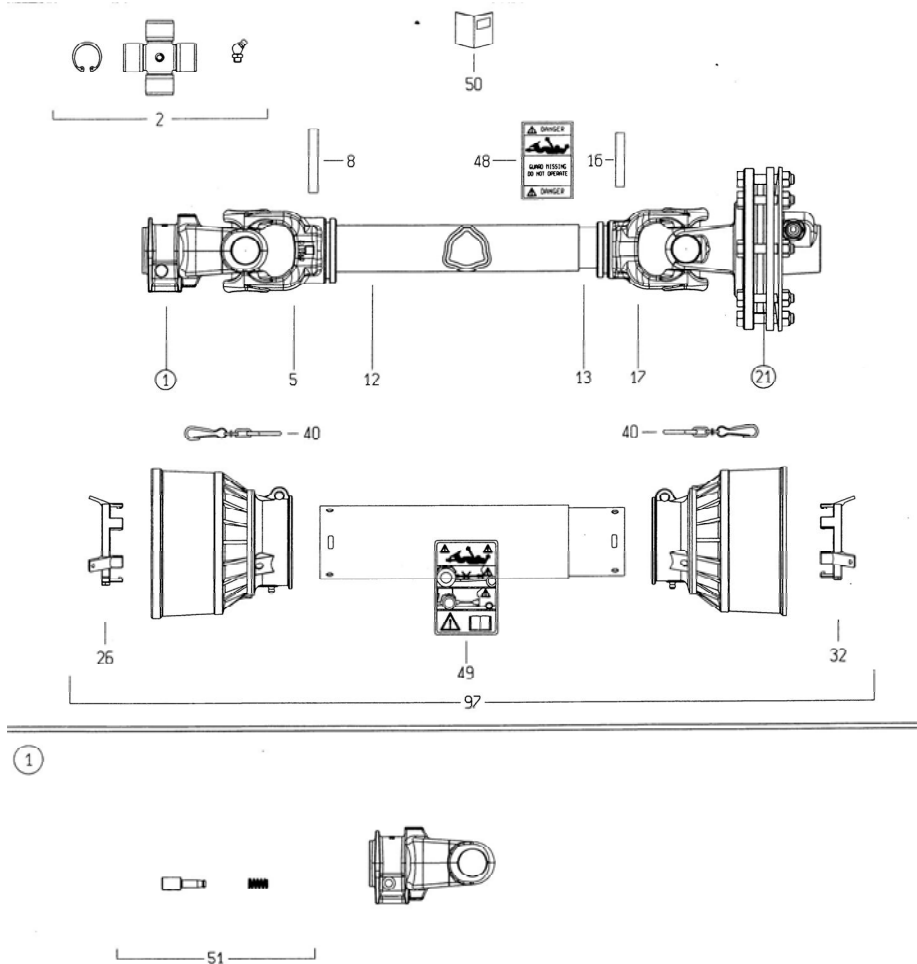

### Topper – plate tensioned clutch

Key no.	Part no.	Quantity	Description
1	3898	8	Bolt and nut
2	3906	1	Flange yoke
3	3900	1	Bush
4	3901	2	Clutch lining
5	3902	1	Hub with taper pin
6	3903	1	Taper pin
7	3904	1	Inner plate
8	3905	1	Belleville spring (tension plate)

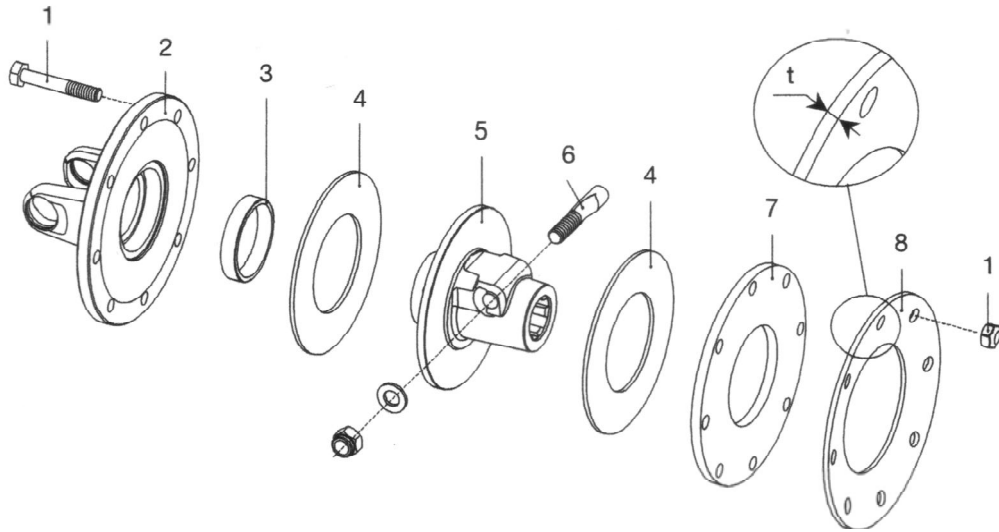



**M32V Topper Gearbox – 45HP**

<b>Key No.</b>	<b>Part No.</b>	<b>Quantity</b>	<b>Description</b>
1	3500	1	Casing
2	3501	1	Cover
3	3502	1	Crown wheel
4	3503	1	Output shaft
5	3504	1	Boss/Hub
6	3505	1	Input shaft
7	3506	1	Cap
8	3507	1	Input oil seal
9	3508	1	Output oil seal
10	3509	1	Breather plug
11	3510	1	Drain plug
12	3511	1	Input bearing (front)
13	3512	2	Output bearing
14	3513	1	Input bearing (back)
15	3514	2	Input circlip
16	3515	2	Output circlip
17	3516	1	Shim
18	3517	1	Output circlip
19	3518	4	Bolts
20	3519	1	Spacer
21	3520	1	Protective washer
22	3521	1	Flat washer
23	3522	1	Split pin
24	3523	1	Castle nut
25	3524	1	Shim
26	3525	1	Level plug
27	3526	1	M32V label plate



**M70V Heavy Duty Topper Gearbox – 75HP**

<b>Key No.</b>	<b>Part No.</b>	<b>Quantity</b>	<b>Description</b>
1	3527	1	Casing
2	3528	1	Input bearing (front)
3	3529	1	Input bearing (back)
4	3530	2	Input circlip
5	3531	1	Output bearing (bottom)
6	3532	1	Input crown wheel
7	3533	1	Output gear
8	3534	1	Input shaft
9	3535	1	Input oil seal
10	3536	1	Cap
11	3537	1	Output bearing (top)
13	3538	3	Drain/level plug
14	3539	1	Cover
15	3540	1	Breather plug
16	3541	1	Output oil seal
19	3542	4	Bolts
20	3543	1	Boss/Hub
22	3544	1	Castle nut
23	3545	1	M70V label plate
25	3546	1	Split pin
26	3547	1	Protective washer
27	3548	1	Output shaft
30	3549	1	Shim
31	3550	1	Split pin
32	3551	1	Flat washer
33	3552	1	Castle nut

# M70V Heavy Duty Topper Gearbox – 75HP

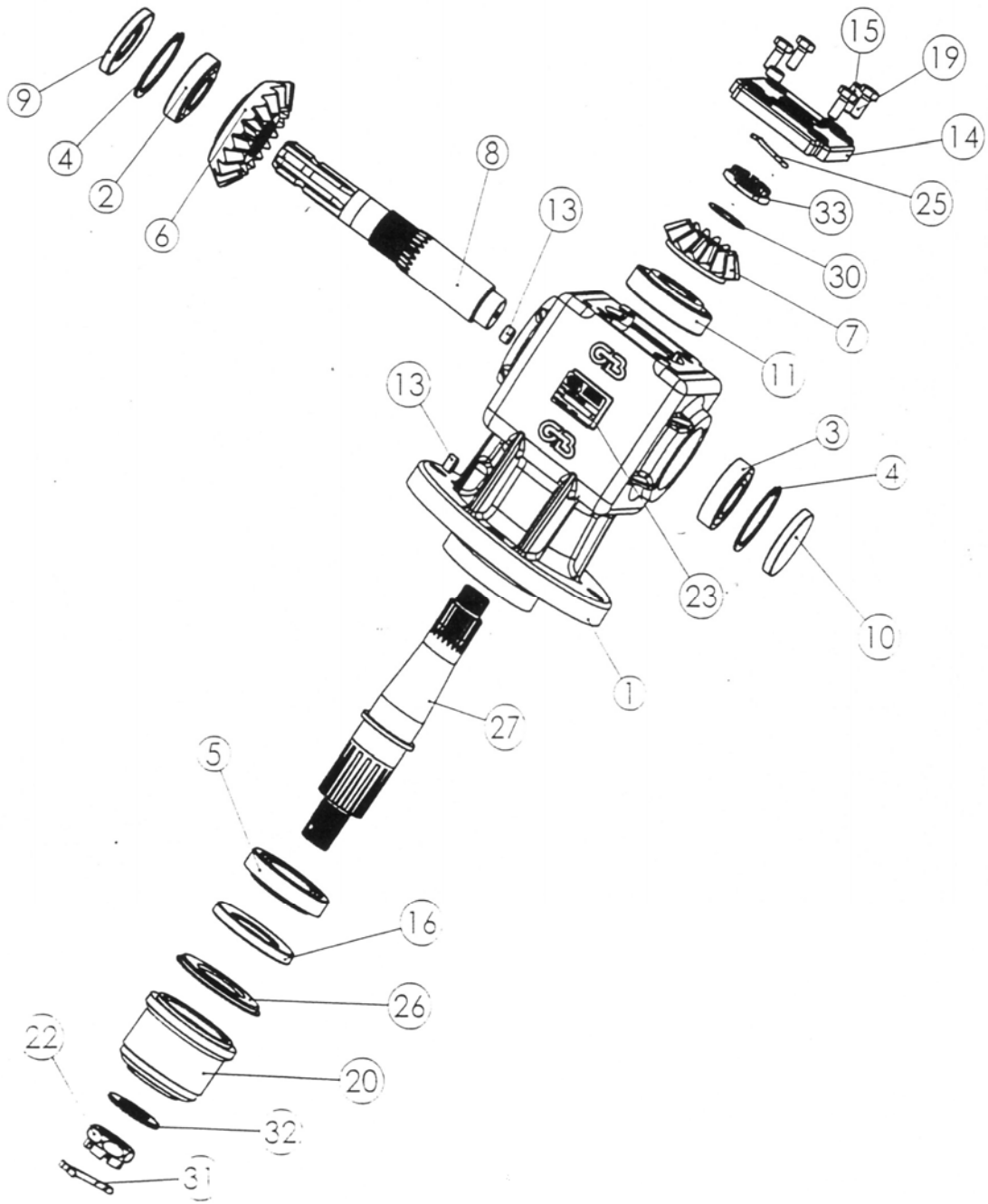

**R50 Centre gearbox 10' pasture topper**

<b>Key No.</b>	<b>Part No.</b>	<b>Quantity</b>	<b>Description</b>
1	3620	1	Casing
2	3621	1	Cover
3	3622	1	Input shaft
4	3623	1	Output shaft
5	3624	2	Input gear
6	3625	2	Output circlip
7	3626	1	Input circlip
8	3627	1	Input circlip
9	3628	2	Input/output bearing
10	3629	2	Input/output bearing
11	3630	1	Input shim
12	3631	1	Input shim
13	3632	1	Input shim
14	3633	3	Input/output seal
15	3634	1	Breather plug 3/8" gas
16	3635	2	Drain/level plug
17	3636	4	Cover bolts
18	3637	1	R50 label plate

R50 Centre gearbox 10' pasture topper

