

John Berends Implements Pty Ltd

AGRICULTURAL ENGINEERS

OPERATOR'S MANUAL PARTS LIST



**STUMP JUMP CHISEL PLOUGHS
RIGID TINE CHISEL PLOUGHS
COIL TINE CULTIVATORS**

PROD NO.

	CHISEL PLOUGHS - STUMP JUMP
0192	5 Tine
0194	7 Tine
0196	9 Tine
0198	11 Tine
	CHISEL PLOUGHS - RIGID TINE
0182	5 Tine
0183	7 Tine
0184	9 Tine
0185	11 Tine
	COIL TINE CULTIVATOR
0202	5 Tine
0204	7 Tine
0206	9 Tine
0208	11 Tine

130 FRANKSTON-DANDENONG RD, DANDENONG SOUTH, VIC. 3175 AUSTRALIA
(ABN 79 007 035 369)

PHONE (03) 9791 2494

FAX NO. (03) 9794 5568

berends@johnberendsimplements.com.au

www.johnberendsimplements.com.au

TABLE OF CONTENTS

	Page No.
SAFETY INSTRUCTIONS.....	3
INTRODUCTION.....	5
SAFETY FEATURES.....	6
ASSEMBLY.....	7
OPERATION.....	7
MAINTENANCE.....	7
SPARE PARTS.....	8





SAFETY





Farm machinery is dangerous if operated incorrectly so please read this manual in its entirety prior to operating the machine.

 No operator, however experienced in farm machinery operation, should attempt to use any machine they have not been competently trained to use. Your local Department of Agriculture can help you with training, as can most Occupational Health and Safety offices, Agricultural schools and colleges and farm equipment dealerships.

 All instructions relating to tractor safety as per the tractor operators manual should be followed. When making any machine adjustments, stop the tractor engine first and wait for all moving parts to stop. Maintain the tractor to ensure it remains safe to use. Do not operate faulty or damaged equipment.

 Extreme caution should be taken when fitting equipment to the tractor's three point linkage. Avoid standing between the implement and the tractor when coupling machinery.

 All machines should be mounted and retained correctly. All guards must be kept in place and correctly maintained. P.T.O. shafts must be correctly attached and secured to both the tractor and the machine. Decals must be visible and legible at all times. Keep well clear of all moving parts.







 Keep all people and animals at a safe distance from all moving parts. Children must not be allowed to operate this equipment and all passengers must have the same level of protection as the operator.

 Wear protective clothing where appropriate.

 Never operate when tired (not alert) or in poorly lit areas and stay alert for humps and other hidden hazards. Remove all timber, rocks and foreign objects prior to operation.

 Avoid operating the machine in wet conditions.

 Exercise extreme caution when changing direction on hills. Avoid sudden movement, sudden breaking, high speeds, rough terrain and steep slopes.

-  If machine starts to vibrate, stop tractor, turn off engine and investigate.
-  After striking a foreign object or if there are doubts about the performance of the machine, stop the tractor as described and check if machine is making excessive noise.
-  Extreme caution must be taken when working in public areas (roadsides etc). It is recommended that flaps and chains are fitted to slashers when operating in public areas. These are available as optional extras. Rear flaps are compulsory in public areas.
-  Watch overhead clearance and beware of underground pipes and cables.
-  Where fitted, hydraulic hoses and fittings must be maintained so as to prevent damage.
-  Do not modify this equipment in anyway, or use it for any other purpose than it was designed to do.
-  Never work under unsupported machines or adjust unsupported machines. Do not enter the danger zone where a load being carried by a machine could fall on you, for example a round bale from a bale fork, a log from a carryall or material from a rear end loader.

These instructions should be used in conjunction with any local regulations regarding safety ie OHS.

Maintenance is essential for safe operation. Ensure maintenance is carried out regularly by people qualified to do so. This is of particular importance on P.T.O. drive machines where driven parts can fly off at high speed if wearing parts are not properly maintained.

FAILURE TO FOLLOW THESE INSTRUCTIONS AND PROCEDURES MAY RESULT IN EQUIPMENT MALFUNCTION, OR DAMAGE, SERIOUS INJURY OR EVEN DEATH.

INTRODUCTION:

This manual was developed specifically for the machine you have purchased. The information within is to assist you in preparing, operating and maintaining your machine. Please read and understand the contents of the manual completely before attempting to operate your machine, paying special attention to all safety details. With our policy of continuous improvement, products and specifications may change without notice and without incurring the obligation to install such changes on any unit previously delivered.

Cultivators

All these cultivators are categorised as primary cultivators. The rigid tine chisel plough is used in clean country where penetration and draft are not a problem. The stump jump ship chisel plough is used in harder conditions. The spring action of the tines provides better penetration. Coil tines are used in similar conditions but do not disturb the surface as much as the stump jump.

MACHINE SPECIFICATIONS

MODEL	Stump Jump	Rigid Tine	Coil Tine
No. Tines/ Discs *	5 - 11	5 - 11	5 - 11
Point/Disc size **	65 x 12mm	55 x 15mm	40 x 16mm
Machine Width	7'9" - 11'9"	7'9" - 11'9"	7'9" - 11'9"
Tractor H.P.	8 -10 H.P./Tine	8 -10 H.P./Tine	6 -10 H.P./Tine

WARRANTY

John Berends Implements P/L warrants each new product sold to be free from defects in material and workmanship, under normal use and service, as outlined in the operators manual, for a period of 12 months.

This warranty is void if any damage to the machine has been caused by misuse or non genuine parts have been used or any repairs have been made by any persons other than authorised dealer service personnel.

The manufacturer/dealer is not obligated to any transportation charges incurred in the repair or replacement of parts.

This warranty does not exclude any condition or warranty implied by the Trade Practices Act 1974 or any other legislation which implies any condition which cannot be excluded.

Safety Features

1. SERIAL NUMBER DECAL



2. WARNING DECAL



3. BERENDS DECAL

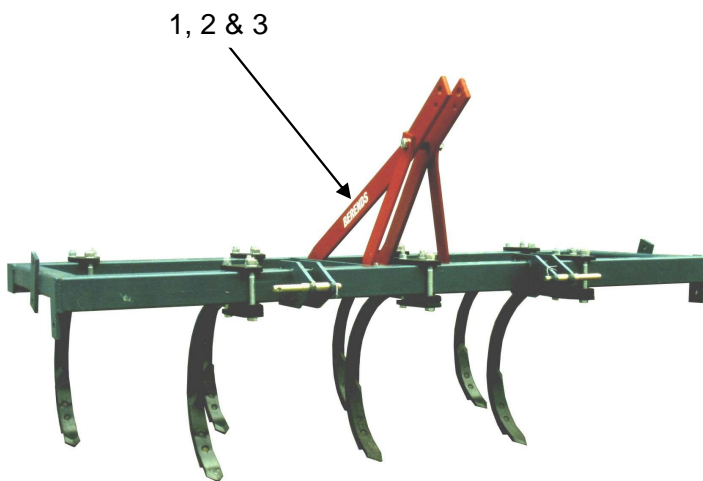
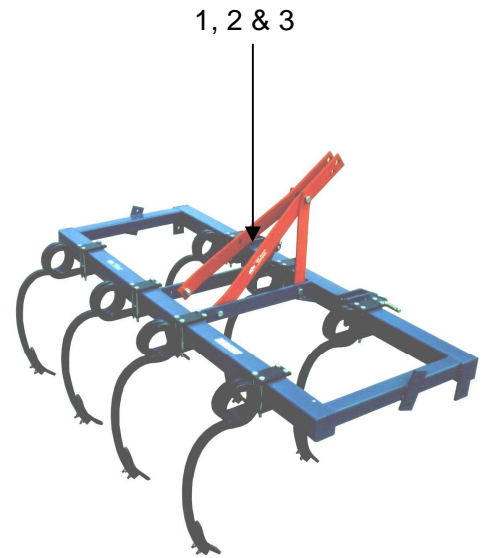
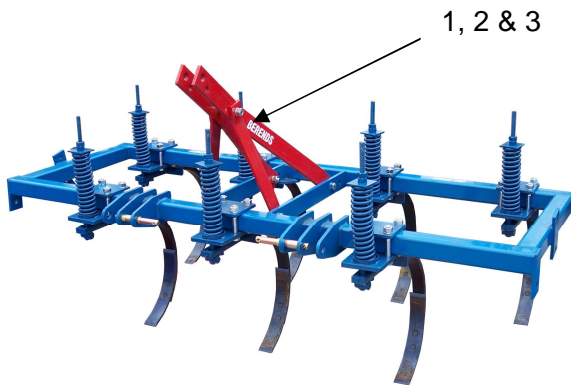

ASSEMBLY

Line the lower linkage arms between the lower linkage plates of the cultivator, slide the linkage pins through the holes and secure with lynch pins. Attach the top link to the cultivator. The lower linkage arms must be level with each other. The tractor top link may need to be adjusted to ensure the cultivator is parallel to the ground when working. However, never have the top link horizontal as this will cause the cultivator to move sideways and make it difficult to track. It may be necessary to remove the tractor drawbar to prevent interference with the tines.

OPERATION

Once all safety procedures have been followed, start the tractor and raise the cultivator off the ground. Ensure the tine spacing is acceptable and all tines are secure.

Turning

Lift the cultivator out of the soil. Never turn before the tines are completely free from the soil, otherwise the inner most tines will be forced sideways and backwards. When making part turns with the cultivator in the soil, you must use so big a circle that the innermost tines never move backward.

Reversing

Never reverse with the tines in the soil, but make sure the cultivator is fully raised. When reversing in the soil the tines can very easily be overloaded, which can later lead to breakages.

Stopping

Lower the cultivator, stop the tractor engine (removing the ignition key) and apply the park brake. Ensure that the cultivator is well supported when not in use.

CAUTION: When the cultivator is on the ground, yet not linked to the tractor, it may be unstable. Make sure something is put in place to keep the machine balanced. ie chock up the linkage with a block of wood.

MAINTENANCE

When doing any type of maintenance on this machine, always follow the safety steps described in this manual. Use only authorised genuine parts for replacement. The cultivator must be adequately supported under its body (Make certain it cannot fall). Check all bolts/nuts regularly as they may loosen under vibration or stress. Ensure the points are not worn down to the tine. All Berends cultivators have reversible points.

Wheel kit

Check tyre pressure. Wheel must run freely on axle and yoke must be lubricated.
Note: Bearings are replaceable if necessary.

SPARE PARTS

ORDER SPARE PARTS THROUGH YOUR ORIGINAL SUPPLIER OR YOUR LOCAL JOHN BERENDS IMPLEMENTS DEALER.

Always quote the machine serial number or product number, spare part number and its part name as stated in the operator's manual.

Glossary of terms

c/w = Complete with
 sw = Spring Washer
 n.s.s. = Not serviced separately
 a.r. = As required
 fw = Flat Washer

Rigid tine chisel ploughs

(For all A-frame components use Stump Jump Chisel Plough breakdown)

Key No.	Part No.	Quantity	Description
1	1651	ar	Rigid chisel plough assy c/w point & clamp suit 100x100
2	1645	ar	Rigid chisel plough shank
3	3805	ar	Rigid chisel plough clamp plates – pair of
4	3806	ar	Clamp plate bolt/nut/sw
5	1641	ar	Reversible point for rigid tine chisel plough
6	1646	ar	Plough bolt/nut for point
7	1970	2	Cat 1/2 stepped pin

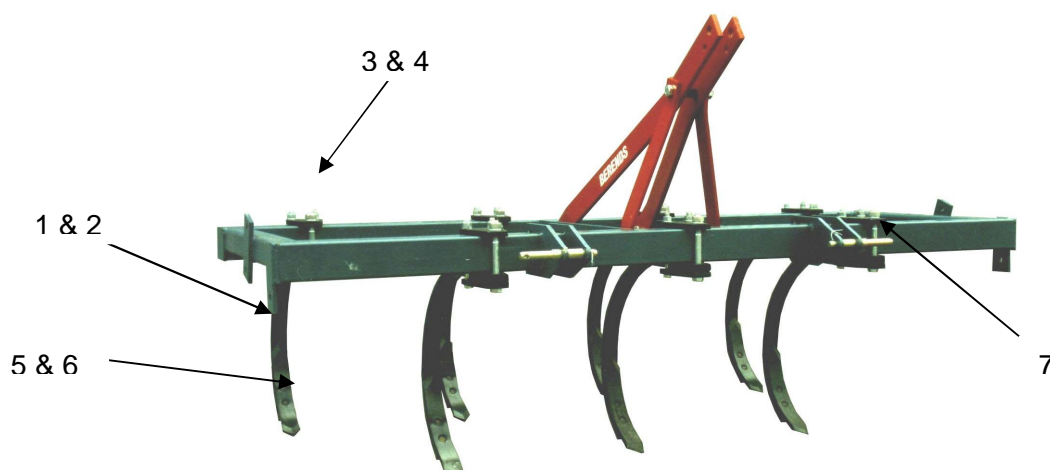

Coil tine cultivator

(For all A-frame components use Stump Jump Chisel Plough breakdown)

Key No	Part No	Quantity	Description
1	1658	ar	30mm square horizontal coil tine assy suit 100 x 100 (specify left or right hand)
2	1657	ar	Reversible point
3	1646	ar	Plough bolt/nut for point
4	3807	ar	Coil tine clamp plates – pair of
5	3809	ar	Clamp plate bolt/nut/sw
6	1659	ar	Shank only
7	1970	2	Cat 1/2 stepped pin

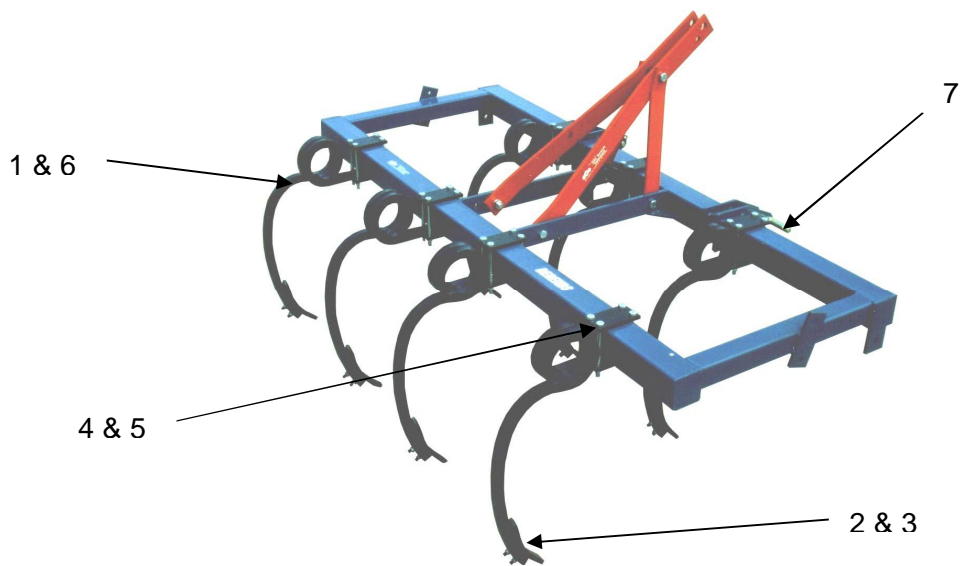

Wheelkit (0200) suit cultivators

Key No	Part No	Quantity	Description
1	3813	2	Main frame (inc. axle) – specify LH or RH
2	3247	2	Rim
	3248	2	Tyre
3	3241	2	Hub (inc. stud/nuts)
4	3814	4	Adjustment bolt/nut/sw
5	3815	2	Mounting bolt/nut/sw

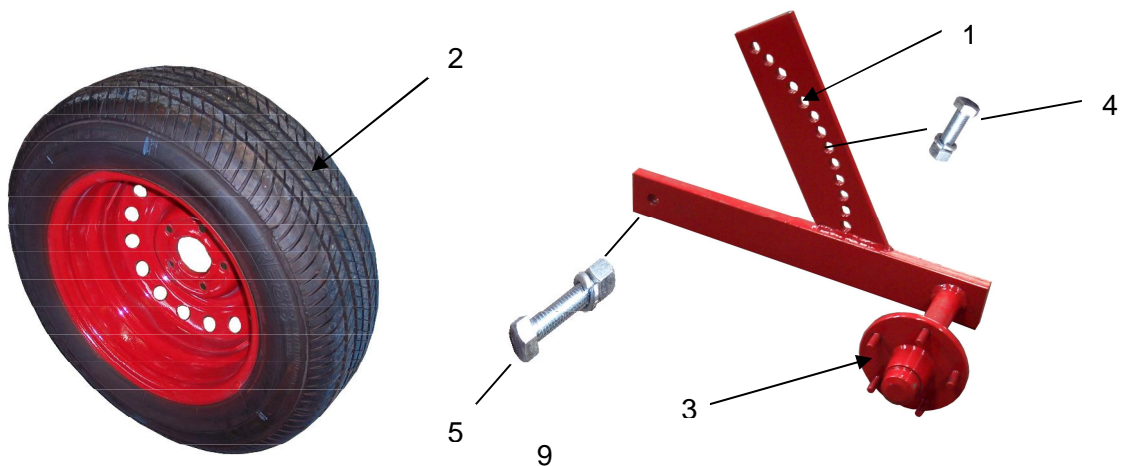

Stump jump chisel plough

Key No	Part No	Quantity	Description
1		1	Chisel plough frame
	1652	ar	Chisel plough tine assembly complete
2	3304	1	'A' Frame bar – RH
3	3305	1	'A' Frame bar – LH
4	3306	2	'A' Frame - short stay
5	3307	1	'A' Frame top link, bolt,nut & spacer
6	3308	2	'A' Frame Bolt/nut/sw (long)
7	3309	2	'A' Frame Bolt/nut/sw (short)
8	1970	2	Cat 1/2 stepped push through pin
9	1642	ar	'T' bolt & 2 nuts
10	3310	ar	Cap
11	1640	ar	Chisel plough spring
12	1959	ar	Pipe for centre of c/plough spring
13	3258	ar	Clamp plate
14	3311	ar	Tine clamp bracket
15	3312	ar	'T' piece
16	3313	ar	Bolt/nut/fw/sw hold 'T' piece to shank
17	1960	ar	Bolt/nut/sw hold c/plough assy to frame
18	1653	ar	Chisel plough shank
19	1644	ar	Reversible point
	1648	ar	10" Duckfoot
	1650	ar	16" Duckfoot
20	1646	ar	Plough bolt/nut suit points

