



John Berends Implements Pty Ltd

AGRICULTURAL ENGINEERS

OPERATOR'S MANUAL PARTS LIST



Standard, Medium & Heavy Duty Grader Blades

PRODUCT NO.

| | |
|------|---|
| 0002 | 4' Grader Blade |
| 0008 | 6' Grader Blade - Standard Fixed |
| 0003 | 6' Grader Blade - Standard Model |
| 0005 | 6' Grader Blade - Medium Duty Model |
| 0006 | 6' Medium Duty Grader Blade with 4 Rippers Attached |
| 0007 | 6' Medium Duty Grader Blade with ratchet tilt |
| 0010 | MD Hydraulic Tilt option – in lieu of ratchet |
| 0414 | 6' MD – 1 ram (angle) |
| 0415 | 6' MD – 2 ram (angle/tilt) |
| 0035 | 6' Grader Blade - Heavy Duty Model |
| 0036 | 7' Grader Blade - Heavy Duty Model |
| 0037 | 8' Grader Blade - Heavy Duty Model |

130 FRANKSTON/DANDENONG RD, DANDENONG SOUTH, VIC. 3175 AUSTRALIA

PHONE (03) 9791 2494

FAX NO. (03) 9794 5568

www.johnberendsimplements.com.au

TABLE OF CONTENTS

| | Page No. |
|--------------------------|----------|
| SAFETY INSTRUCTIONS..... | 3 |
| INTRODUCTION..... | 5 |
| SAFETY FEATURES..... | 6 |
| ASSEMBLY..... | 7 |
| OPERATION..... | 7 |
| MAINTENANCE..... | 9 |
| SPARE PARTS..... | 10 |





SAFETY





Farm machinery is dangerous if operated incorrectly so please read this manual in its entirety prior to operating the machine.

 No operator, however experienced in farm machinery operation, should attempt to use any machine they have not been competently trained to use. Your local Department of Agriculture can help you with training, as can most Occupational Health and Safety offices, Agricultural schools and colleges and farm equipment dealerships.

 All instructions relating to tractor safety as per the tractor operators manual should be followed. When making any machine adjustments, stop the tractor engine first and wait for all moving parts to stop. Maintain the tractor to ensure it remains safe to use. Do not operate faulty or damaged equipment.

 Extreme caution should be taken when fitting equipment to the tractor's three point linkage. Avoid standing between the implement and the tractor when coupling machinery.

 All machines should be mounted and retained correctly. All guards must be kept in place and correctly maintained. P.T.O. shafts must be correctly attached and secured to both the tractor and the machine. Decals must be visible and legible at all times. Keep well clear of all moving parts.

 Keep all people and animals at a safe distance from all moving parts. Children must not be allowed to operate this equipment and all passengers must have the same level of protection as the operator.

 Wear protective clothing where appropriate.

 Never operate when tired (not alert) or in poorly lit areas and stay alert for humps and other hidden hazards. Remove all timber, rocks and foreign objects prior to operation.

 Avoid operating the machine in wet conditions.

 Exercise extreme caution when changing direction on hills. Avoid sudden movement, sudden breaking, high speeds, rough terrain and steep slopes.

 If machine starts to vibrate, stop tractor using method as described in the operation section

 After striking a foreign object or if there are doubts about the performance of the machine, stop the tractor as described and check if machine is making excessive noise.

 Extreme caution must be taken when working in public areas (roadsides etc). It is recommended that flaps and chains are fitted in these areas. These are available as optional extras. Rear flaps are compulsory in public areas.

 Do not modify this equipment in anyway, or use it for any other purpose than it was designed to do.

 Never work under unsupported machines or adjust unsupported machines. Do not enter the danger zone where a load being carried by a machine could fall on you, for example a round bale from a bale fork, a log from a carryall or material from a rear end loader.

These instructions should be used in conjunction with any local regulations regarding safety ie OHS.

Maintenance is essential for safe operation. Ensure maintenance is carried out regularly by people qualified to do so. This is of particular importance on P.T.O. drive machines where driven parts can fly off at high speed if wearing parts are not properly maintained.

FAILURE TO FOLLOW THESE INSTRUCTIONS AND PROCEDURES MAY RESULT IN EQUIPMENT MALFUNCTION, OR DAMAGE, SERIOUS INJURY OR EVEN DEATH.

INTRODUCTION:

This manual was developed specifically for the machine you have purchased. The information within is to assist you in preparing, operating and maintaining your machine. Please read and understand the contents of the manual completely before attempting to operate your machine, paying special attention to all safety details. With our policy of continuous improvement, products and specifications may change without notice and without incurring the obligation to install such changes on any unit previously delivered.

Standard, Medium & Heavy Duty Grader Blades

All of this range of grader blades are available with angle and tilt functions. The blade can be rotated 360 degrees with 24 different positions. The tilt function is operated by adjusting the linkage pin mounting positions. The 0007 MD grader blade has additional tilt through the ratchet or optional hydraulic ram. The standard model, medium duty model and heavy duty model all come with offset functions. Rippers are available on the medium duty model if requested. All models are available with an optional wheelkit for depth control which is adjustable from the tractor seat. All blades are fitted with heavy duty hardened reversible cutting edges.

MACHINE SPECIFICATIONS

| MODEL | Compact | Compact | Std Fixed | Std Model | MD Model | HD Model |
|------------------------|------------|------------|------------|------------|------------|-------------|
| Cutting Edge Width | 4' | 5' | 6' | 6' | 6' | 6', 7' & 8' |
| Mouldboard Thickness | 6mm | 6mm | 6mm | 6mm | 8mm | 10mm |
| Mouldboard Height | 350mm | 350mm | 350mm | 350mm | 450mm | 500mm |
| Tractor H.P. | 16-35 H.P. | 16-35 H.P. | 20-50 H.P. | 20-50 H.P. | 30-60 H.P. | 40-100 H.P. |
| Tractor CAT connection | Cat 1 | Cat 1 | Cat 1/2 | Cat 1/2 | Cat 1/2 | Cat 1/2 |
| Nett Weight (kg) | 101 | 115 | 160 | 180 | 200 | 305-370 |
| No. offset positions | 0 | 0 | 10 | 10 | 10 | 8 |
| No. angle positions | 24 | 24 | 24 | 24 | 24 | 24 |

WARRANTY

John Berends Implements P/L warrants each new product sold to be free from defects in material and workmanship, under normal use and service, as outlined in the operators manual, for a period of 12 months.

This warranty is void if any damage to the machine has been caused by misuse or non genuine parts have been used or any repairs have been made by any persons other than authorised dealer service personnel.

The manufacturer/dealer is not obligated to any transportation charges incurred in the repair or replacement of parts.

This warranty does not exclude any condition or warranty implied by the Trade Practices Act 1974 or any other legislation which implies any condition which cannot be excluded.

Safety Features

1. SERIAL NUMBER DECAL

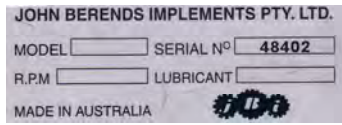

2. WARNING DECAL



3. BERENDS DECAL

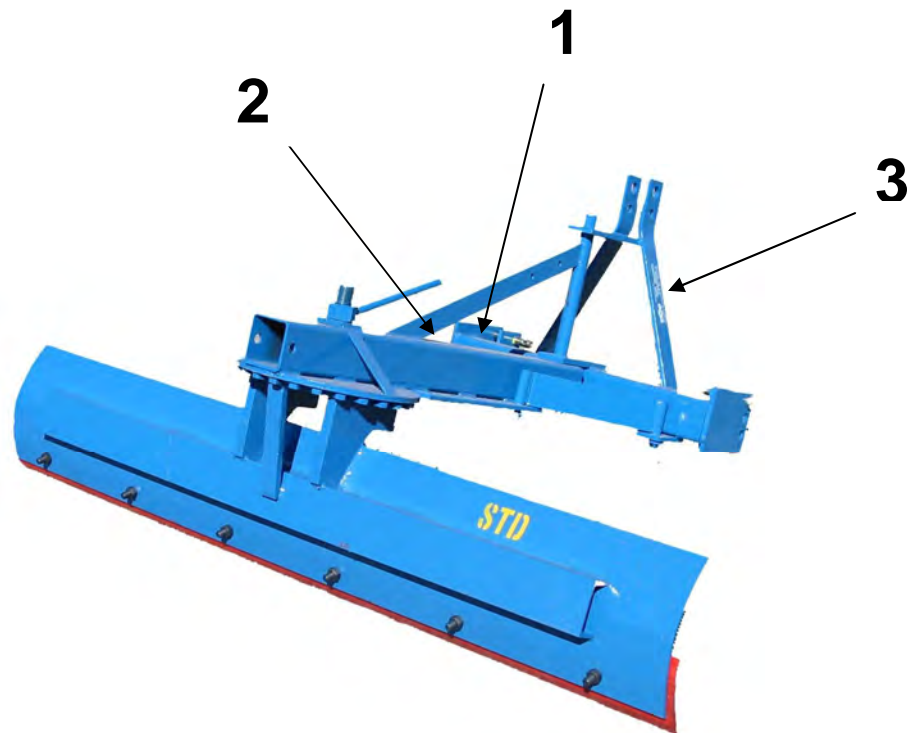

ASSEMBLY

Line the lower linkage arms between the lower linkage plates of the implement, slide the linkage pins through the holes and secure with linch pins. Ensure the lower arms of the tractor have an anti-sway device fitted such as stays or chains. This prevents the implement from swinging side to side during transport. Failure to do so may result in damage not covered by warranty.

Attach the top link to the implement.

(Note: Top link pins and linch pins are not supplied by Berends)

OPERATION

Once all safety procedures have been followed, start the tractor and raise the grader blade off the ground

Offset Adjustment

There are four positions of offset on either side of the blade (except for the compact blade and the standard fixed model). The offset adjusting arm has to be mounted on the side on which the blade is required to be offset, left for left and right for right. It is adjusted by fitting the pin at the mouldboard end of the adjusting arm in one of the four alternative holes in the beam. To do this level the machine so it will not swing around under its own weight, then remove the pin, move the blade beam across until the hole in the offset arms lines up with a hole in the beam at the desired offset.

Angle Adjustment (non hydraulic model)

The blade is locked in position by a locking lug under the beam.

On the Standard and Medium Duty models this blade is held tight by the pivot nut handle. Loosen the handle so that the blade drops below the locking index. This is best done by lifting the machine slightly off the ground using the linkage arms on the tractor. Rotate the blade to the desired angle and ensure the angle adjustment handle (nut handle) is secure.

On the Heavy Duty models the angle arrangement is slightly different. To change the angle of the blade this locking lug is released by pulling on the lever situated on top of the blade beam near the main pivot for the blade angle. This lever has a hole at the top so a rope can be fitted to allow the lever to be operated from the tractor seat if required. The blade is not supplied with a rope. With the lever pulled down the blade can be swung around 360 degrees, the blade simply needs to be moved to the required angle and the lever released. The locking plate will locate in the nearest locking tooth as it is spring loaded.

Caution:

When adjusting any blade angle or offset, make sure the machine is level so it will not swing around under its own weight.

Angle Adjustment (optional hydraulic model)

The blade is fitted with a hydraulic cylinder to control the angle. First ensure that the main nyloc nut on top is tightened so that there is no play in the blade but not so tight that the blade can't turn. It is advisable that this is tested manually before connecting the hydraulic ram. The

piston end (moving end) of the ram should be connected at the mouldboard. Do not adjust the angle whilst grading.

Tilt Adjustment (non hydraulic)

The Standard, Medium and Heavy Duty model blades all tilt via the linkage pins. When connecting the grader blade position the tractors lower linkage arms in different holes to vary the tilt. The blade can be tilted from the tractor using the levelling box without altering the pins. Also as you generally have the blade on a fairly acute angle to carry soil up out of the drain, the top link can be shortened to give even more tilt.

The MD model (0007) has tilt adjustment through a ratchet handle at the rear of the blade.

Tilt Adjustment (optional hydraulic)

The blade is fitted with a hydraulic cylinder to control the tilt. The piston end (moving end) of the ram is mounted at the central mounting position underneath the turntable. Do not adjust the tilt whilst grading. Ensure all hoses are free from entanglement with the blade as it goes through its motions. It may be necessary to cable tie the hoses out of the way.

Depth Adjustment

The depth wheel is adjusted through either a wind-up handle or a ratchet, depending on the model. The wheel is normally to control the depth, particularly on the final pass. It is normally positioned 10mm below the cutting edge height. The depth can be then finely adjusted by lowering or raising the 3 point linkage.

When reversing the blade, it is important the wheel is lifted off the ground. Failure to do so may lead in damage to the wheel when going through undulating ground.

General grading

Take care when grading. Ensure that the tractor is the right configuration for the job. Too small a tractor can result in tipping the tractor and too large a tractor can result in damage to the blade. Be extremely careful when operating in uneven or unstable ground.

Always remove foreign objects before grading. Graders are not designed for pulling out rocks, stumps and roots so always assess the job beforehand to see if the blade and tractor are suitable for the job.

Reverse/back blading

Take care when operating the mouldboard in the reverse position. The structural design of the headstock is such that most of its strength and support is for when going forward. When the tractor is pushing the blade, there is much more force on the unit as well as reduced relief in the flotation of the linkage arms. In heavy going of where there may be foreign objects in the ground – the strength is considerably reduced. It is advised that this function only be used for loose grading such as backfilling holes or pushing loose dirt into a pile.

Stopping

Lower the grader blade, stop the tractor engine (removing the ignition key) and apply the park brake. Ensure that the grader blade is well supported when not in use.

MAINTENANCE

When doing any type of maintenance on this machine, always follow the safety steps described in this manual. Use only authorised genuine parts for replacement. The grader blade must be adequately supported under its body (Make certain it cannot fall).

Cutting Edge

Ensure that the cutting edge is not worn past the bottom of the supporting mouldboard. Before it reaches this point, you must remove the cutting edge and turn it upside down or replace with a new one. Failure to do so may result in unnecessary wear to the mouldboard.

Wheel kit

Check tyre pressure. Wheel must run freely on axle and yoke must be lubricated. Note: Bearings are replaceable if necessary.

Hydraulic Fittings and Hoses

Before doing any maintenance on the hydraulic system, release the oil pressure. Be careful when searching for oil leaks as oil escaping under pressure can be invisible and may penetrate the skin.

If leaving the grader blade outside for an extended time it is advisable that the chrome cylinder rods be lubricated with an appropriate lubricant to prevent corrosion.

Clean all dirt and foreign matter away from the rods prior to using so that seals do not become contaminated.

SPARE PARTS

ORDER SPARE PARTS THROUGH YOUR ORIGINAL SUPPLIER OR YOUR LOCAL JOHN BERENDS IMPLEMENTS DEALER.

Always quote the machine serial number or product number, spare part number and its part name as stated in the operator's manual.

Glossary of terms

c/w = Complete with
 sw = Spring Washer
 n.s.s. = Not serviced separately
 a.r. = As required
 fw = Flat Washer

4' and 5' Grader Blade 0002/0016

| Key No. | Part No. | Quantity | Description |
|---------|----------|----------|--|
| 1 | 1500 | 1 | 4' Cutting edge |
| | 3862 | | 5' Cutting edge |
| 2 | 1508 | 4 or 5 | Bolt and nut to suit cutting edge |
| 3 | 1514 | 1 | Grader blade nut handle (angle adjustment) |
| 4 | 1969 | 2 | Cat 1 push thru linkage pin |
| 5a | 1918 | 1 | Locking index (3 teeth welded on to underside of beam) |
| 6 | 1493 | 1 | Pivot pin |

6' Std Fixed Grader Blade 0008

| Key No. | Part No. | Quantity | Description |
|---------|----------|----------|---|
| 1 | 1502 | 1 | 6' Cutting edge |
| 2 | 1508 | 6 | Bolt and nut to suit cutting edge |
| 3 | 1514 | 1 | Grader blade nut handle (angle adjustment) |
| 4 | 1967 | 2 | Cat 1 bolt on pin |
| 5b | 1934 | 1 | Locking index (3 teeth welded to underside of beam) |
| 6 | 1496 | 1 | Pivot pin |

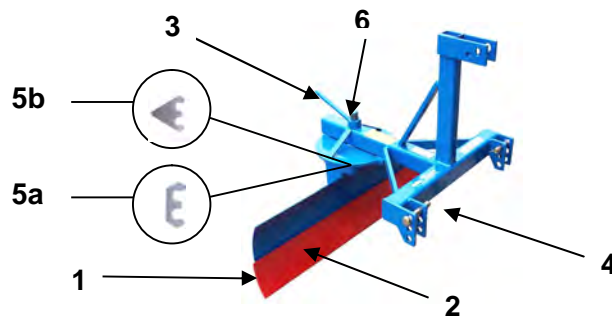

6' Std Grader Blade 0003, 6' MD Grader Blade 0005 & 6' MD GB with Rippers 0006

| Key No. | Part No. | Quantity | Description |
|---------|----------|----------|---|
| 1 | 1502 | 1 | 6' Cutting edge |
| 2 | 1508 | 6 | Bolt and nut to suit cutting edge |
| 3 | 1514 | 1 | Grader blade nut handle (angle adjustment) |
| 4 | 1516 | 1 | Offset arm (inc. R-clips) |
| 5 | 1934 | 1 | Locking index (three teeth) welded to underside of beam |
| 6 | 1969 | 2 | Cat 1 push through pin |
| 7 | 1491 | 1 | Cog (angle) complete with pivot pin/support legs |
| 8 | 1496 | 1 | Pivot pin |
| 9 | 1518 | 1 | Ripper Kit (set of 4 tines & 4 wedges) |
| | 1519 | ar | Ripper only |

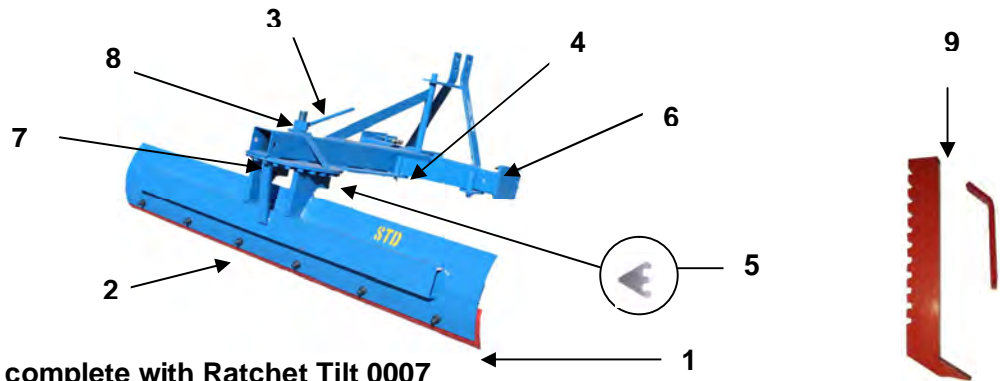

6' MD Grader Blade complete with Ratchet Tilt 0007

| Key No. | Part No. | Quantity | Description |
|---------|----------|----------|---|
| 1 | 1502 | 1 | 6' Cutting edge |
| 2 | 1508 | 6 | Bolt and nut to suit cutting edge |
| 3 | 1514 | 1 | Grader blade nut handle (angle adjustment) |
| 4 | 1516 | 1 | Offset arm (inc. R-clips) |
| 5 | 1934 | 1 | Locking index (three teeth) welded to underside of beam |
| 6 | 1969 | 2 | Cat 1 push through pin |
| 7 | 1977 | 1 | Cog complete with pivot pin (welded in) & legs suit MD Tilt |
| 8 | 1496 | 1 | Pivot pin |
| 9 | 1979 | 1 | Tilt pin (with R-clip) |
| 10 | 3210 | 1 | Ratchet (inc. clevis pins/clips) |

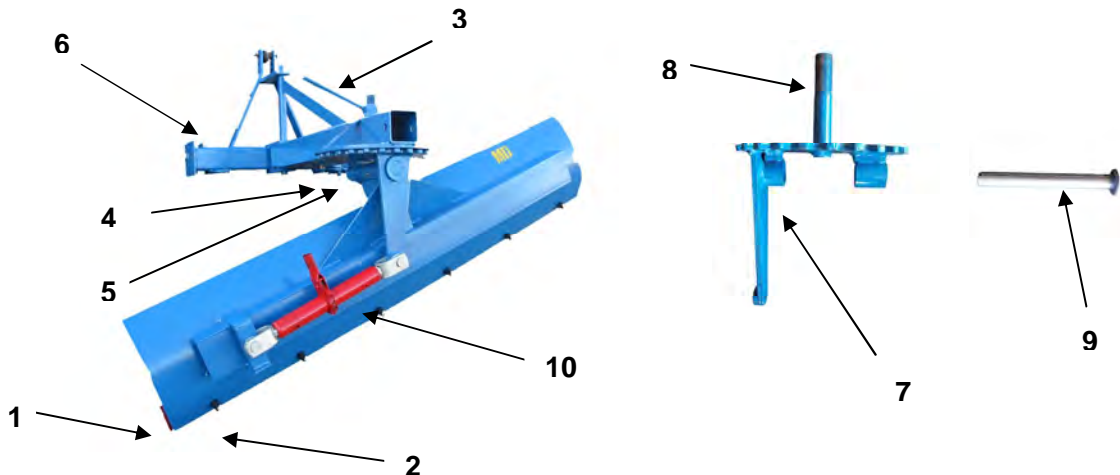

6' Heavy Duty Grader Blade 0035
8' Heavy Duty Grader Blade 0037

7' Heavy Duty Grader Blade 0036

| Key No. | Part No. | Quantity | Description |
|---------|----------|----------|---|
| 1 | 1502 | 1 | 6' Cutting edge |
| | 1504 | 1 | 7' Cutting edge |
| | 1506 | 1 | 8' Cutting edge |
| 2 | 1508 | ar | Bolt and nut to suit cutting edge |
| 3 | 1933 | 1 | Locking index (three teeth) inc. bolt/nut/washers |
| 4 | 1939 | 1 | Spring, suit locking index |
| 5 | 1971 | 2 | Cat 1/2 stepped push through pin |
| 6 | 1497 | 1 | HD pivot pin (2") |
| 7 | 1494 | 1 | HD pivot nut |
| 8 | 1490 | 1 | HD cog (complete with pin & support legs) |
| 9 | 1484 | 1 | Angle adjustment lever |
| 10 | 1481 | 1 | Stand (inc. R-clip) |
| 11 | 1483 | 1 | Offset arm |
| 12 | 1482 | 2 | Offset arm pins (inc. R-clip) |

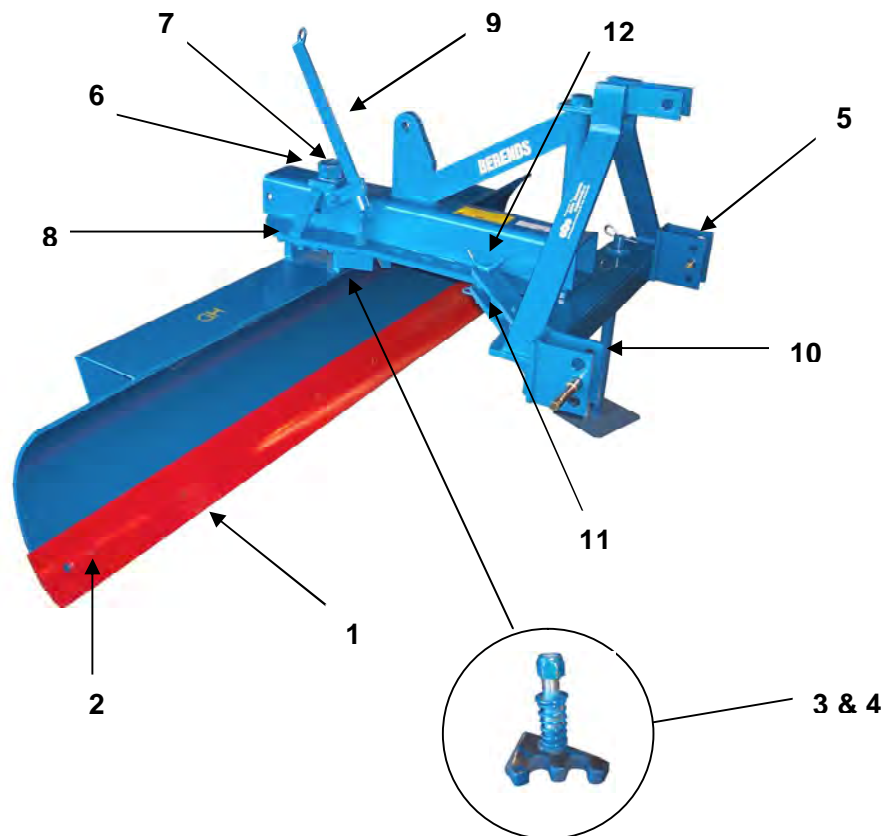

Wheel kit suit Std and MD grader blades 0009

| Key No. | Part No. | Quantity | Description |
|---------|----------|----------|---|
| 1 | 1510 | 1 | Wheel and tyre assy |
| 2 | 1512 | 1 | Yoke and axle |
| 3 | 1939 | 1 | Spring |
| 4 | 1940 | 1 | Linch Pin |
| 5 | 1913 | 1 | Threaded Handle (inc. mounting bracket) |
| 6 | 3863 | 1 | T-Piece suit 6' standard model |
| | 3864 | 1 | T- Piece suit 4' & 5' model |
| 7 | 3865 | 1 | Cat 1 Top link (replaces Key No.5 for 4' and 5' models) |

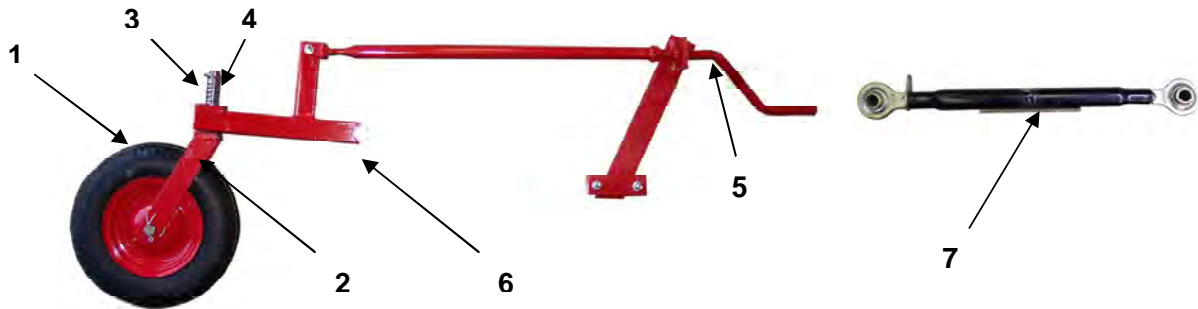

Wheelkit suit Heavy Duty Grader Blades 0026

| Key No. | Part No. | Quantity | Description |
|---------|----------|----------|------------------------|
| 1 | 1802 | 1 | Main arm |
| 2 | 1803 | 1 | Yoke & sleeve |
| 3 | 1804 | 1 | Axle (inc. studs/nuts) |
| 4 | 1927 | 2 | Wheel bearing |
| 5 | 1965 | 2 | Bearing housing |
| 6 | 3247 | 1 | Rim |
| | 3248 | 1 | Tyre |
| 7 | 3210 | 1 | Ratchet |

