

2015

FENDT

Fendt 300 Vario

310 • 311 • 312 • 313



A class for generations.

The new Fendt 300 Vario. Yes.

The 300er series has been uniting the experience of generations with the demands for the highest quality and performance. Whether in the grassland, in the field, during transport or for municipal work – equipped with even more comfort, features and efficient technology, the Fendt 300 Vario is your reliable companion for the daily challenges of your work.

That is why we say: Yes. Because the Fendt 300 Vario offers everything that you need. See for yourself and say yes to the compact all-round tractor.

Fendt 310 Vario	110 hp	81 kW
Fendt 311 Vario	119 hp	88 kW
Fendt 312 Vario	129 hp	95 kW
Fendt 313 Vario	138 hp	102 kW

Maximum output to ECE R 24

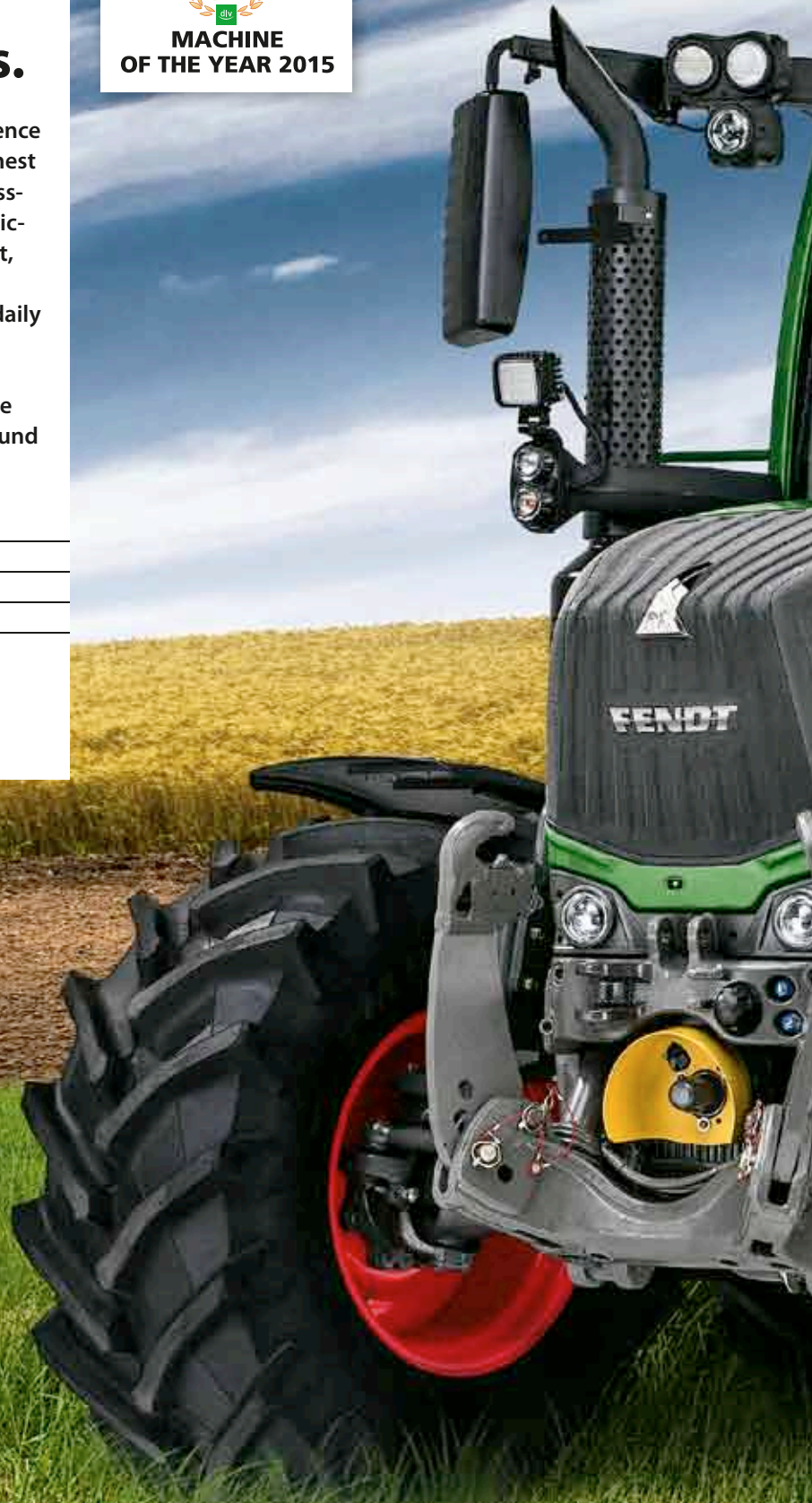



The new Fendt 300 Vario

Lots of space? Everything in view? Yes.

Comfort and controls like in the big ones: with the VisioPlus cab and easy to operate Variocentre, the Fendt 300 Vario fulfils all desires for comfort and practicality. You will immediately feel at home in the new cab. Driver and passenger seat, visibility, controls and suspension – the entire body of the cab has been thought out thoroughly from the ground up and designed for your well-being and optimal working conditions.



 The Fendt VisioPlus cab expands your field of vision: 77° upward visibility for a full view of the completely raised front loader. The optional parallel wiper ensures a clear view through the large windscreen.



Fendt Varioterminal 7-A: you can operate all the functions of your tractor easily, e.g. also ISOBUS implements (Profi version), with just one control unit.





Individualised equipment

Fendt 300 Vario. Just right.

Those who are already familiar with the manoeuvrable compact tractor know how much it can do. The Fendt 300 Vario offers the right features for the application. Choose the best solution for you from the Power and Profi equipment variants.

The Fendt 300 Vario Power offers you the right equipment features for versatile applications in the areas of grassland operations, arable farming, transport, cultivation, specialty crops, municipal work and, last but not least, as a farmyard tractor. It convinces through robustness and durability. The Fendt 300 Vario Profi provides that certain something to give you the added comfort and function necessary for your special working requirements and to make your daily work easier.





Fendt 300 Vario Power

Flexibility and efficiency in one.

In the Power equipment line, the new Fendt 300 Vario features numerous elements for flexible and efficient operations. Operation is straightforward and easy using the Variocentre, from hydraulic applications to electronics. The Fendt 300 Vario is controlled using a joystick. In addition to speed regulation, the two-gate joystick has many useful functions that are directly at hand, for example, the reverser, automatic linkage, engine speed memory and two cruise control speeds.

The spacious VisioPlus cab offers you additional comfort and a lot of visibility all around the tractor. The panoramic windscreen provides a 77 degree viewing angle. You have a continuous field of vision to the right, since there is no B-pillar to get in the way. Towards the rear, you have a full view to the rear linkage and implements. The ergonomic arrangement of the operating elements allows you to control the Fendt 300 Vario Power easily and conveniently.



More power



- Powerful engine with 4.4 l cubic capacity
- High maximum torque
- Emissions standard EU Stage 4 / TIER 4 final
- Tank capacity 210 l diesel and 23 l AdBlue

More functions



- Front PTO with wet clutch for a longer lifetime
- Front linkage with higher lift capacity up to 3,130 daN
- New front axle suspension The longitudinal arm enables more pulling power and permits a larger steering angle

More comfort



- VisioPlus cab for the best visibility and more space 6.2m² glazing and 2,520-l air space
- One-piece panoramic windscreen with 77° field of vision
- Controlled with Vario joystick with 5 functions and Variocentre

Fendt 300 Vario Profi

Like a big one.

With the Fendt 300 Vario Profi, you have a compact tractor that makes daily work flexible and efficient. Additionally, it now offers more features. You can control the Fendt 300 Vario Profi with a multi-function joystick, just like a Fendt from one of the high-horsepower series. With a 110-litre LS control pump, the hydraulics have a high volume capacity at a low engine speed.

The certain something

The controls on the 300 Profi set it apart: The Varioterminal 7-A brings together all the tractor and implement controls onto one screen. With the Variotronic^{TI} headland management, which is integrated in the Varioterminal, you can save up to 1,920 hand movements in 160 turning manoeuvres.



More power



- 110-l control pump for a higher delivery capacity at a lower rpm
- Automatic maximum output control with kick-down mode for dynamic driving with immediate acceleration
- Fendt CargoProfi front loader with work height limiting, weighing and shaking functions

More functions



- Straight-forward operation with Varioterminal 7-A
- Variotronic^{TI} headland management for fewer hand movements at the headlands
- Electric valves with time and flow control

More comfort



- Pneumatic cab suspension
- LED work lights
- External controls for rear and front linkage are standard
- Multi-function joystick with Variotronic implement control ISOBUS

We present you our special solutions

A holistic approach.

The whole is more than just the sum of its parts. It is the perfect interplay of all the elements that complement each other for an optimal result. That is what makes a tractor a Fendt.

Notably Fendt. Simply better in detail.

We have an eye on the whole. And optimise every detail for it. We develop solutions that make sure you can make more happen – easier, faster and simpler.

Look for the Fendt Spotlights! They show you what makes a Fendt special.

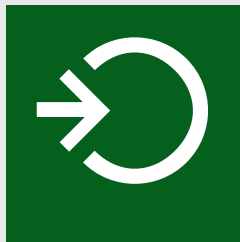



Fendt Spotlights: This icon stands for notable solutions from Fendt. Solutions that help you every day, which we will explain to you in further detail.



Look for the exceptional solutions: the special features of a Fendt are marked as spotlights.



VisioPlus cab

-  Spacious cab with 2,520 litres of air space and a curved panoramic windscreen for a large 77-degree field of vision.
-  Comprehensive lighting concept (optionally with LED) for the best illuminating power with a long lifetime and low power consumption.
-  Fully integrated Variocentre for straightforward and intuitive operation via the Varioterminal, joystick and illuminated keyboard.



Vehicle body

-  The rugged, waisted half-frame design provides more space for a large steering angle. That makes the Fendt 300 Vario even more manoeuvrable. The front power lift is fully integrated in the half-frame and has a lift capacity of 3,130 daN. Foldable lower links ensure more space when working with a front loader.

Engine and transmission

-  High-capacity air filter with intake through the cooler unit for best air flow and high efficiency.
-  Automatic maximum output control 2.0 for the optimal engine speed according to power requirement. The kick-down mode accelerates the tractor quickly for fast starting off.

Mounting areas

-  Load-sensing pump with a 110-litre delivery capacity at reduced engine speed for swift work with hydraulic implements.
-  Front linkage with load relief control for optimal implement guidance; advantage when working with a snow plough or front mower.

The assemblies on the Fendt 300 Vario



Your favourite place with a wide view

The place where you spend so much of your time has to be just right. That starts when entering the cab and certainly doesn't just stop when driving. We have thought your operating sequences through precisely. The best solution: the VisioPlus cab. Comfortable entry, high comfort, ergonomic arrangement of the operating elements– and with more visibility and space. That will make the new cab on the Fendt 300 Vario one of your favourite places.



"Driving is a lot of fun, because the tractor is easy to operate. You can find your way around immediately and the cab is so comfortable. The machine is simply fantastic!"

Robert Rager, dairy farmer and
Fendt driver from Southern
Germany





You simply see more.

Clear view to the outside

You can also enjoy our VisioPlus cab in the Fendt 300 Vario for unobstructed visibility. The panoramic windscreen in the new cab is a great help in keeping an overview. The front window, without cross bar, curves up into the roof. That triples the viewing angle: With 77 degrees, you have an unobstructed upward view – even to the completely raised front loader. A door is available for the right-hand side for even more flexible entering and exiting. If you prefer a windscreen that opens,

there is also one available for the Fendt 300 Vario with a divided window pane. In the VisioPlus cab you have a total of 6.2 m² of glazing for continuous all-round visibility without a B-pillar to get in the way. The wide-angle mirror integrated in the main mirror enlarges the field of view, especially to the traffic towards the rear. In the Profi version, electrical adjustment and heating is available as an option for the mirrors.



Sight angle



➔ One-piece panoramic windscreen with 77° sight angle for an unobstructed view in all directions and to the wheel arches.

VisioPlus cab



➔ The clearly laid out and ergonomically designed VisioPlus cab offers the best overview, both to the operating elements and the field. The windscreen is available as a continuous panoramic window or a hinged pane. An additional door can be chosen in place of the right side part.

Wide-angle mirror

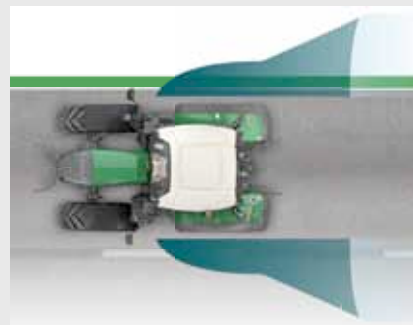

➔ The wide-angle mirror is integrated on the main mirror as secondary mirror and expands the field of view considerably.

Window wiper



Segment wipers with intermittent operation or parallel wipers for an even larger wiper field.

More light for night owls

The Fendt 300 Vario brings a lot of light into the dark with its new lighting concept. The crossed front halogen work lights perfectly illuminate all objects on both sides – irrespective of the implements. The Power version can be upgraded with work lights. Two rear work lights are integrated in the roof as standard in the Profi version, upon request they are also available as LED lights. LED lights are marked by especially low power consumption, stronger illuminating power and a long

lifetime. Safety on the road: The newly designed bi-halogen headlights generate the best light for the main and dipped beams. All keys on the armrest also have interior lighting with night dimming – that makes working in the dark safer.



 The entire lighting concept, with up to six work lights for the rear alone, offers exceptionally good illumination for safe and comfortable work, even in the dark. For those who need extra bright lights and would also like to save power, can choose the Fendt 300 Vario with LED work lights.

Interior lighting



 Controlled by a light sensor, the lighting for the indicators and operating elements adapts to the current light conditions.

Cross-eyed lights



 The crossed front work lights shine overlapping light cones on all objects in the front area and also optimally illuminate the implements. This prevents any glare, e.g. caused by reflections on the exhaust pipe.

The Fendt VisioPlus cab

- Large cab with a 2,520-litre volume for an exceptional sense of space
- Curved, one-piece panoramic windscreen with a 77° sight angle for an unobstructed view
- Narrow, compact bonnet for best all-round visibility
- Parallel wiper for a larger field of view
- Heated rear window with rear window wiper
- Illuminated control console on the right armrest
- LED work lights
- Crossed work lights for optimal illumination in the front
- Wide-angle mirror for the best view to the traffic behind
- Opaque roller shade over the entire width of the window

The most comfortable second home

More space to enjoy life

The new Fendt VisioPlus cab offers plenty of space for your comfort. This already starts when you climb up into the cab on the wide step treads. With more than six square metres of glazing, the cab is not only visually larger – you also have a greater sense of space thanks to the 2520-litre air space and the well thought-out ergonomic arrangement of all the components. All operating elements are easy to reach. Numerous storage spaces provide practical stowing options.

Superior comfort

A perfectly coordinated cab suspension is the basis for safe and comfortable driving and working. The mechanical cab suspension minimises vibrations effectively. The optionally available pneumatic cab suspension in the Profi version absorbs vibrations and also provides pneumatic levelling at the rear. The air-suspended comfort seat adjusts to your weight and absorbs all shock loads. The super comfort variant with seat heater also has pneumatic lumbar support. The cushioned passenger seat with backrest is invit-

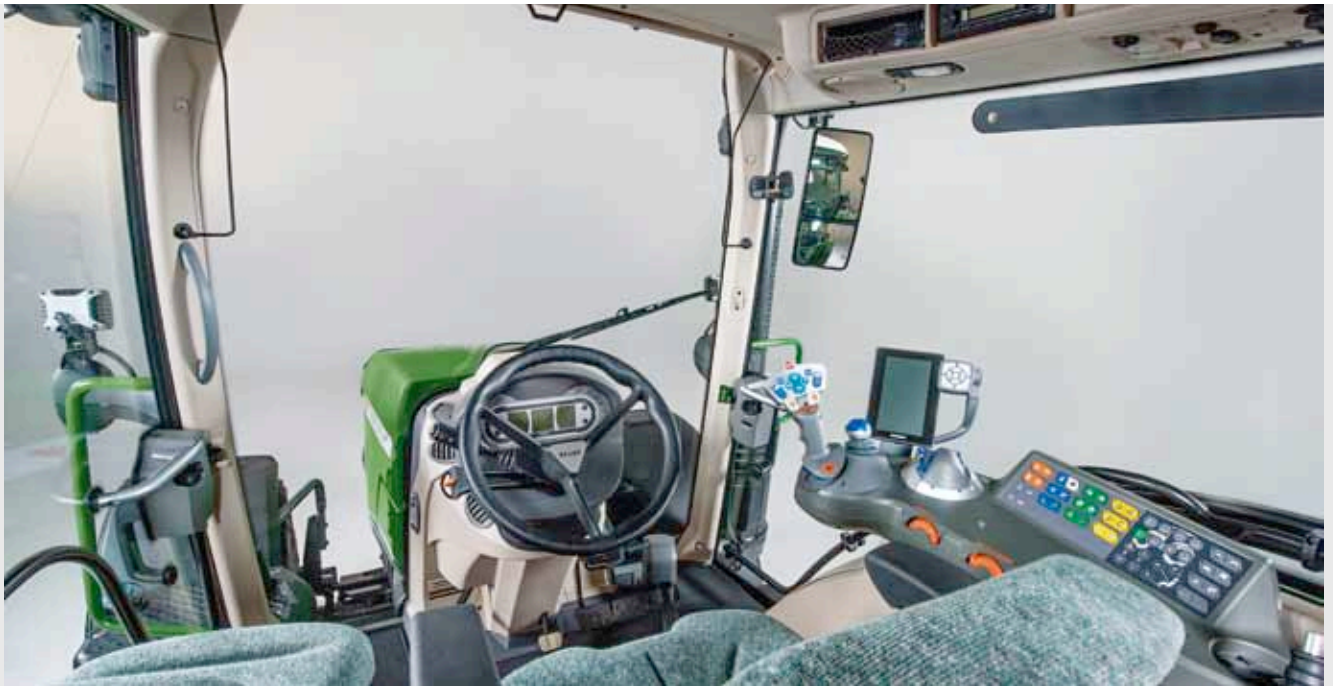

Driver seat



All operating elements are within optimal reach of the driver seat. The suspension system and the individual armrest adjustment ensure comfortable work days. In addition to the standard specification comfort seat with air suspension, an optional super comfort seat with seat heater, pneumatic lumbar support and rotary adapter is also available.

Passenger seat



The comfort passenger seat with backrest and safety belt offers passengers safety and comfort for long work days.

Cab suspension



The pneumatic cab suspension (Profi equipment level) reduces vibrations to a minimum and provides high ride comfort. It is supported on four points with integrated self-levelling: the cab rests on two conic bearings at the front and on two air spring elements at the rear.

ing. The height and tilt-adjustable steering column can be easily adjusted to the perfect position with the foot pedal. Joystick, linkage control and membrane keypad are completely integrated in the Variocentre and operated with the right hand. The standard equipment for the Fendt 300 Vario Power includes a manually adjustable air-conditioning system. The Profi version has automatic climate control for optimal temperature regulation. Now the only thing left to do is: climb in, feel good, get going.

Integral cable lead-through



➡ Cables can be led neatly into the cab from the outside. The cable lead-through protects the inside of the cab against dirt, water and noise. Cable holders on the C-pillar complete the system.

Roof hatch



The hatch integrated in the roof liner offers additional ventilation on hot days. A sight-optimised bracket on the right-hand side provides a place for additional implement terminals.

Automatic climate control & lighting



➡ All lights can be easily assigned to illuminated keys on the control console and actuated with the touch of a button. The integrated air conditioning ensures optimal cooling and comfort – manually controlled in the Power variant, upon request fully automatic control in the Fendt 300 Vario Profi.

Entry steps



Wide step treads permit safe and easy entering and exiting. The door handle is easy to reach from the ground.

Steering wheel position



➡ For an optimal sitting position, the steering wheel must be at the right height and tilt angle. The cockpit, including the steering wheel, is individually adjustable.

Cooling compartment



➡ You surely would not want to do without the comfort of a cooling compartment for drinks. On hot days, cool refreshments are always well within reach behind the passenger seat.

Simply work efficiently: Fendt 300 Vario Power

A holistic approach. Well thought-out to the last detail.

A holistic approach, in combination with its consistent implementation across all key machines, is what defines the Fendt operating concept as a whole. Well thought-out to the last detail, but always with an eye on the whole, you experience intuitive operation and functionality across all ranges.

Operation made easy

Operating the Fendt 300 Vario Power is straightforward and easy using the fully integrated Variocentre. The Vario joystick, the power lift module and the illuminated keypad are combined in a clearly laid out control console. The arrangement and colour coding of all the operating elements corresponds to the current Fendt tractors and guarantees across-range, easy and fast operation. The entire membrane keypad is backlit and ensures safe operation in the dark.

Variocentre (Power)

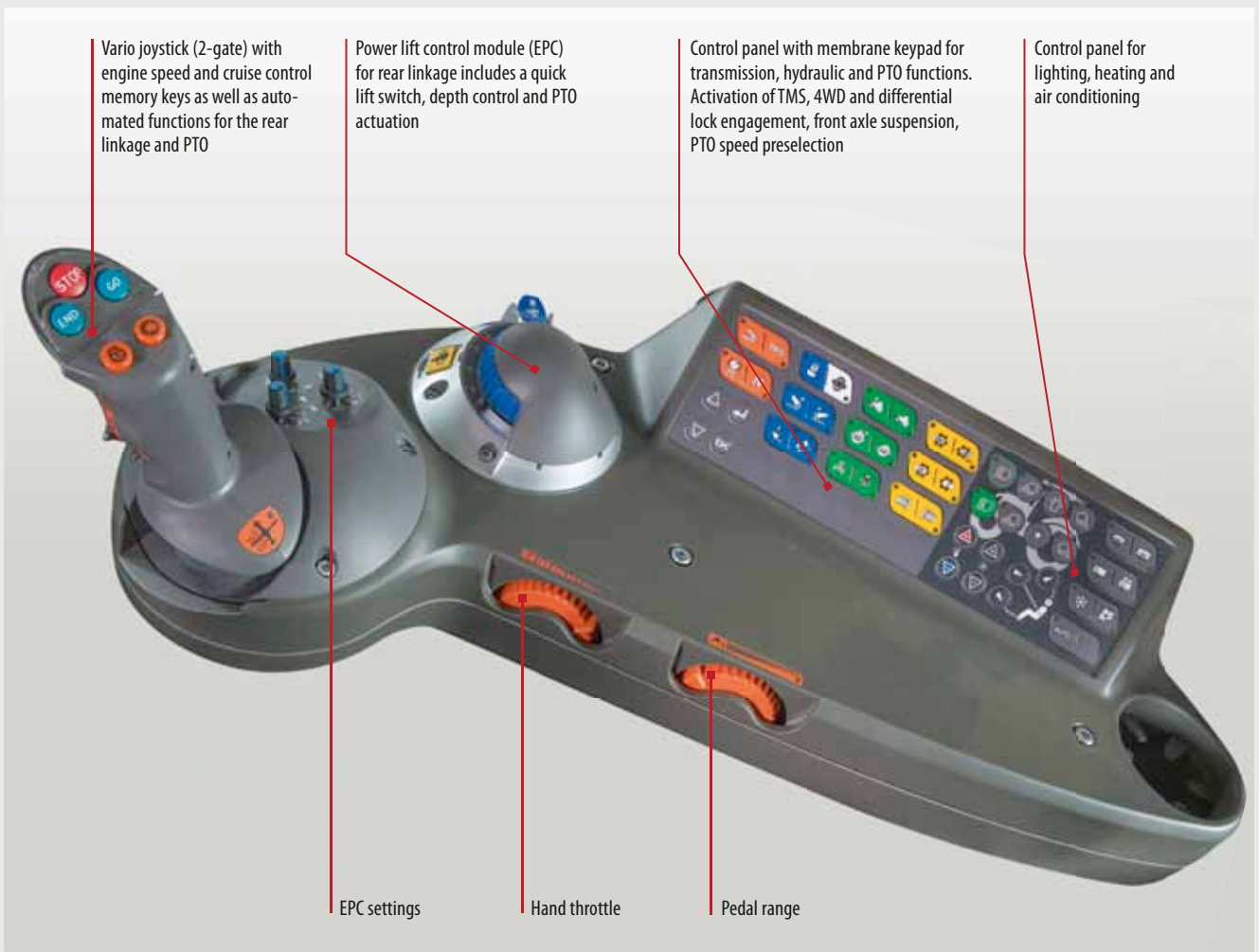

The consistent overall control concept, comprising the Power joystick, power lift control module and membrane keypad, is the ergonomic control centre which allows the operator to keep everything under control.

The lighting is controlled using conveniently located keys. A big advantage is the central button for switching on and off all of the lights at once.

2-gate Vario joystick

You can control the transmission, shuttle control and cruise control with the 2-gate Vario joystick. There are five auxiliary functions: automatic linkage control, two cruise controls, one speed memory as well as the shuttle control and the acceleration rate.

Hydraulic valve actuation



The mechanical spool valves are in comfortable reach, directly next to the driver seat. The crossgate lever controls the yellow and blue valves, for example, for ideally coordinated front loader operations. The flow volume for the red and yellow valves can be optimally adjusted using the rotary control.

Socket



Diverse sockets for the direct supply of power and the transmission of speed signals are attached in the roof liner where they are conveniently located and well protected.

Settings rear power lift (EPC)



Rotary controls for setting the maximum lift height for the rear linkage, the lowering throttle and the position-draft mixed control.

2-gate Vario joystick



 With the two-gate Power joystick, you can control all the driving functions of the Fendt 300 Vario, including the reverser and cruise control activation through a movement to the right. With the joystick, you can also directly operate the automatic linkage control (Go, End), acceleration ramps, engine speed memory and two cruise control speeds.

Fendt Variocentre (Power)

- Fully integrated Variocentre for straightforward operation of all functions.
- Fast overview thanks to colour coding for the hydraulic, engine, transmission and PTO functions
- Ergonomic arrangement of all operating elements on the right mudguard.
- Vario joystick for easy and direct control with five functions
- Power lift module with quick lift switch, depth control wheel, PTO and stop key.
- Completely backlit membrane keypad for safe work in the dark

Smart efficiency: Fendt 300 Vario Profi

Fendt Variotronic control

For the first time, the intelligent Variotronic electronic solutions have found their way into the Fendt 300 Vario class. With the first generation of the Varioterminal, Fendt already set new standards for agricultural equipment back in 1998. Now the demands on the terminal functions have become significantly higher. At the same time, it must remain easy to use. Fendt's answer is Variotronic.

Seamless operation

The Varioterminal 7-A brings all the tractor and implement controls together onto one screen. The 17.8 cm display provides an optimal overview over all running functions, which you can adjust with a click of a button on the display: the hydraulic functions, e.g. linkage and valves; the transmission functions, e.g. cruise control speeds; the engine speed and engine speed memory. The flat menu structure and the straightforward displays offers fast and intuitive orientation. The terminal has a

Variocentre (Profi)



The consistent overall control concept, comprising the Power joystick, power lift control module and membrane keypad, is the ergonomic control centre which allows the operator to keep everything under control.

total of 25 memory spaces for individual implement settings. Using the optional integral interface, all ISOBUS capable implements can be operated with the Varioterminal, so additional implement terminals are not needed.

Headland turns made easy: Fendt Variotronic™

Electronic assistance is a real benefit, especially for headland management. With our Variotronic™ you save up to 1,920 hand movements in 160 turns. You can program up to 20 settings into the terminal for each turning manoeuvre at the headland, both when standing still and when driving. Later all it takes is a touch of a button to activate the automated procedures at the headland – you can therefore drive without have to reposition your hand.

Varioterminal 7-A



➡ The Varioterminal 7-A unites all the tractor controls, conveniently and functionally, in one terminal. The display, featuring a smartphone design, shows all running functions on a 17.8-cmscreen diagonal with 65,000 colours and a resolution of 480 x 800 pixels. You can navigate easily and quickly through the complete menu using the arrow keys.

Hydraulic crossgate lever



➡ The crossgate lever operates the front loader, for example. The buttons for the third and fourth circuits are well within reach of the index and middle finger.

Power lift control module



The front lift also has its own valve disc, which means the front linkage does not occupy any of the four spool valves.

Multifunction joystick



➡ With the two-gate multi-function joystick, you can operate the Fendt 300 Vario like one of the Fendt high-horsepower tractors. The multifunction joystick offers additional control of the 3rd and 4th valves with floating position, headland management (Go, End), second key engine speed memory and cruise control memories C1 and C2.

Fendt Variocentre (Profi)

- Ingenious Variotronic operating interface like on the Fendt high-horsepower tractors
- Varioterminal 7-A with intuitive menu navigation and ease of operation
- All functions are clearly integrated in just one terminal
- ISOBUS implements can be operated via Variotronic implement control
- Headland management Variotronic™ with programming when stationary and when driving
- Controlled with two-gate multifunction joystick for easy driving and fast operation

Engine and transmission

Top Team.

Makes teamwork a joy: lively four-cylinder engine and stepless Vario transmission – you will no longer want to drive anything else. Equipped with a 4.4-litre AGCO Power engine, the new Fendt 300 Vario convinces with higher torque and more pulling power. The engine and the Vario transmission work highly efficiently and with low fuel consumption. The stepless Vario speed adjustment is very precisely coordinated, making the tractor pleasant and easy to drive. The Fendt Vario transmission has proved itself about 200,000 times in operation since 1995.



“We started with one Fendt 300 Vario, and now we have four. These machines do really good work every day, and they are top in terms of fuel consumption.”

Andrew Herron, arable farmer and Fendt driver from Ireland





Yes, this drive is a joy.

Lively and efficient.

The power range of the Fendt 300 Vario goes from a maximum output of 110 hp to 138 hp with a top speed of 40 km/h. The AGCO Power 44 AWF HD engine delivers more power and torque in the 300er class. The all-round tractor is extremely fuel-efficient: The low rated speed of 2,100 rpm and a new cooler unit with a high-capacity air filter ensure high efficiency with low fuel consumption.

Economical and environmentally friendly

Also saves on emissions: The SCR exhaust technology with AdBlue exhaust gas treatment proves to be especially fuel-efficient. The additional injection of the urea solution AdBlue reduces nitrogen oxides to a minimum. In combination with a diesel oxidation catalyst (DOC) and the exhaust gas recirculation (AGRex), emissions are reduced effectively and the tractor complies with the newest Stage 4 / Tier 4 Final emissions standards.

Engine characteristics – Fendt 313 Vario Exhaust gas after-treatment

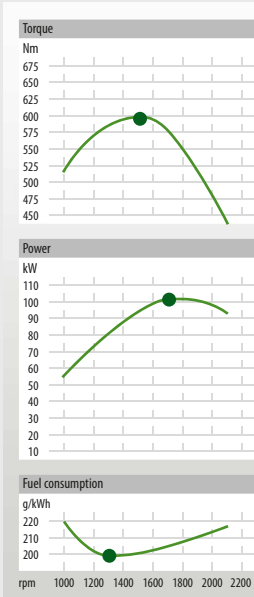

AGCO Power 44 AWF HD (EGR) engine with four cylinders and 4,400 cm³ cubic capacity, 596 Nm torque, 138 hp maximum output, rated speed of 2,100 rpm and a specific fuel consumption of 199 g/kWh.

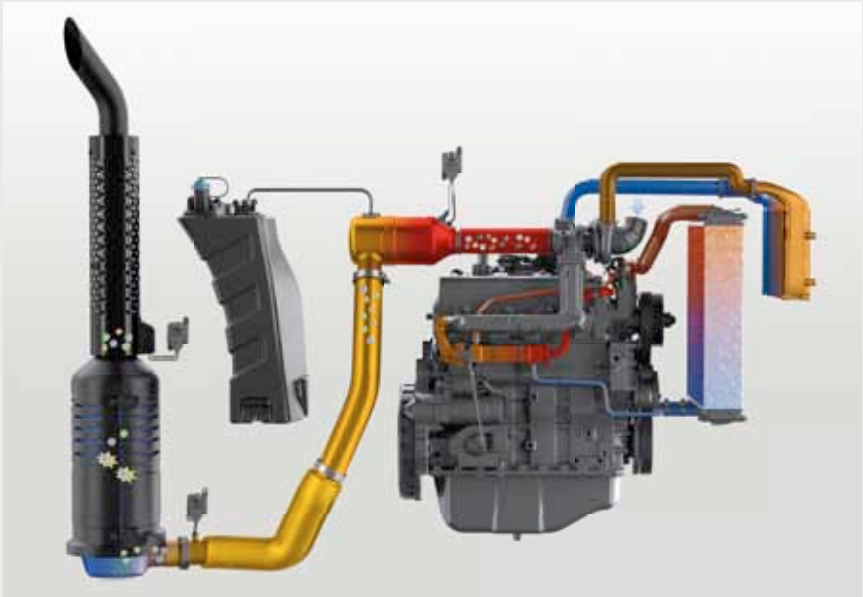

SCR (Selective Catalytic Reduction) for exhaust gas after-treatment

With SCR technology, exhaust is after-treated with AdBlue®, a 32.5 percent solution of urea, which converts nitrous oxides NO_x into non-toxic nitrogen and water.

Maximum engine efficiencies are achieved through ideally coordinated components: exhaust turbocharger with water-cooled wastegate actuator, fuel pre-filter with thermostatic valve and air intake via a bonnet, which provides for a high air flow without requiring an intake pipe on the cab pillar. The fuel consumption indicator not only monitors the current consumption, but also logs the consumption for different operations. Furthermore, it assists the operator in maintaining an efficient driving style.

 The fuel pre-filter with thermostatic valve allows the tractor to start reliably, even when outside temperatures are very low. The radiator and filter are arranged for ease of maintenance.

The large and easily accessible radiators run at a low fan speed, which lowers fuel consumption.

Radiator Filter AdBlue



Well laid out cooler unit for easy access.



 The high-capacity air filter ensures optimal air intake and cleaning. The air filter is easy to exchange.



The extremely fine atomisation through a 6-hole injector nozzle effectively reduces AdBlue consumption.

Stepless driving pleasure

The stepless Vario transmission guarantees ride comfort and savings potential. Continuously variable, without having to shift, the transmission permits speeds from 20 metres per hour to 40 km/h. You always work at the exact speed that perfectly matches the work. This provides enhanced performance that will always remain outside of the grasp of power shift transmissions. The tractor is easy to drive, either per joystick or with the pedal. The Vario transmission and engine are designed for low fuel consumption. The Fendt 300 Vario Profi

offers fully automatic maximum output control, where the engine speed reduction is determined according to the power demand. The engine is therefore always operating in the ideal engine speed range. Operators can also adjust the maximum output control 2.0 manually, if they wish. The kick-down mode, where the tractor accelerates similar to a passenger car with automatic transmission, means the tractor takes off swiftly.

Fendt Vario transmission

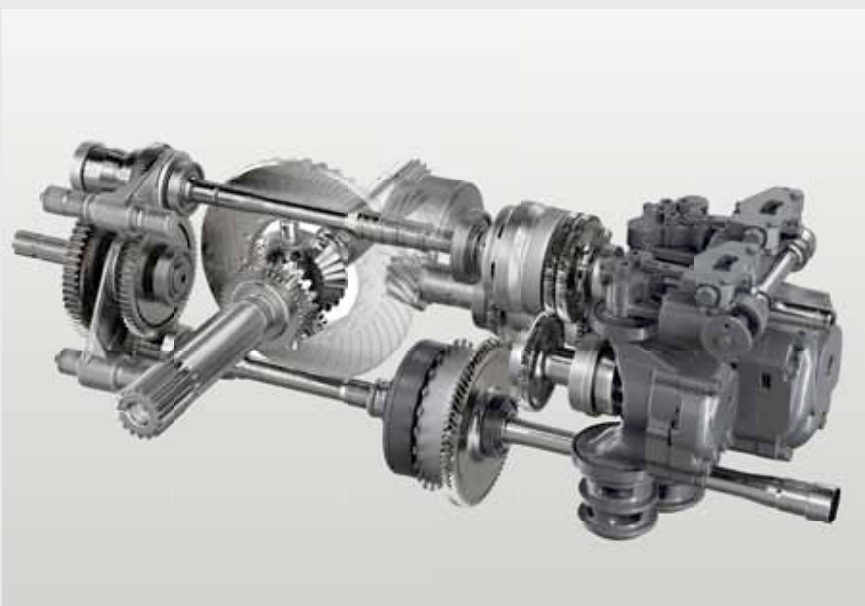

The ingenious Fendt Vario transmission is a hydrostatic-mechanical power split drive. With increasing speed, the share of the mechanical power transmitted through the planetary set increases. Power splitting and hydrostats that swing 45 degrees ensure outstanding efficiency.

Joystick / Pedal



➡ The driving mode can be selected individually: The speed can be controlled with either the pedal or the joystick.

Reverser lever



Drive direction can be changed with either the joystick or the steering column switch with integral stop and go function.

TMS / max. output control 2.0



The Tractor Management System TMS controls the engine speed and transmission ratio to minimise fuel consumption as far as possible.

Cutting-edge engine and transmission technology

- Four-cylinder 4.4 litre engine and common rail injection for a high maximum output of up to 138 hp
- SCR exhaust technology for compliance with emissions standard EU Stage 4 / Tier 4 Final
- Low rated speed of 2,100 rpm for low fuel consumption
- More pulling power through high torque of 485 - 596 Nm
- Vario transmission for stepless driving from 0.02 to 40 km/h
- Large tank capacity for long work days: Diesel: 210 litres AdBlue: 23 litres
- Tractor Management System TMS and automatic maximum output control 2.0

Vehicle body

Designed for hard work

Just what you need for a successful work day: The Fendt 300 Vario meets all your requirements for robustness and flexibility. Higher traction and even higher ride comfort through the new front axle suspension with longitudinal arm, 4WD automatic and the 100% differential locks in both axles – the more in function that makes your work easier, from field to transport operations.



"I've been driving Fendt since I was a kid and already rode along with my father and grandfather. The steering assist and easy manoeuvring makes driving with the Fendt 300 Vario especially comfortable."

Romain van Goethem,
dairy farmer and Fendt driver
from France





Strong base for high demands

A chassis that convinces

The entire chassis concept of the Fendt 300 Vario has been designed for flexible operation and ride comfort, from field operations to transport.

- Smooth ride through self-levelling front axle suspension with longitudinal arm
- Automatic 4WD and differential lock control with steering angle sensors
- 100% disc locking front/rear
- Robust half-frame construction
- Improved manoeuvrability through larger steering angle

Safe driving, even with high payloads

The new Fendt 300 Vario is based on a robust cast half-frame, which is designed for a permissible overall weight of 8,500 kg and a high payload of over 3,500 kg. The space-saving half-frame design creates the space required for the new suspension with longitudinal arm, which provides especially high ride comfort. The waisted design of the half-frame creates more space for a substantially larger steering angle, which means greater manoeuvrability. The front lift is also optimally integrated in

“Waisted” half-frame with rigid front axle



The waisted cast half-frame of the Fendt 300 Vario is the rugged base for the entire tractor – engine, cooler unit, front linkage, front PTO and front axle are mounted on the half-frame. Thanks to the stable construction, larger axle loads are permissible. The waisted design permits a larger steering angle.

Wheel lock



➡ The waisted half-frame without protruding parts and the front axle suspension with longitudinal arm permit an exceptional steering angle. Thanks to the pivoting mudguard, the steering angle can be fully utilized.

Front axle suspension

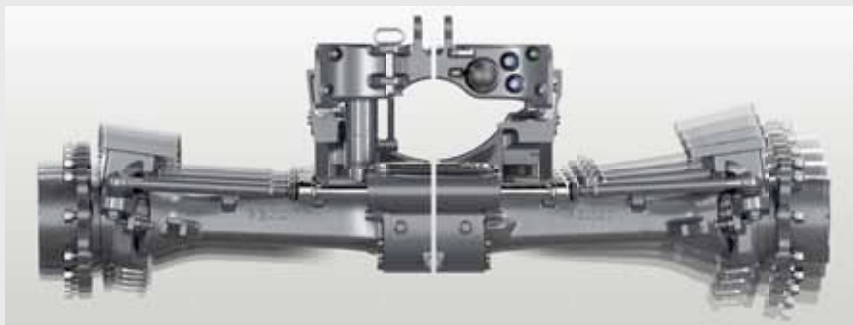

The compact half-frame design permits smooth front axle suspension, installation of a longitudinal arm with a suspension cylinder, and a lift capacity of 5.2 tonnes. The suspended longitudinal arm improves transmission of pulling power by up to 7% and thus ensures higher area coverage. Self-levelling provides constant ride comfort, even with varying loads, and optimises the view towards the front.

Tyres



➡ Wider tyres up to 540/65 R24 in the front and up to 600/65 R38 at the rear and an optimal weight distribution ensure the best pulling power and is gentle on the soil. Row crop tyres with large diameter provides high ground clearance.

the half-frame design and the front loader can be mounted directly on the frame. For more safety when driving with trailers, the Fendt 300 Vario Profi offers an optional automatic steering axle lock for the self-steering axle on tandem trailers.

Also fast in curves

The Fendt Reaction steering system provides easy and sensitive steering for especially smooth and safe handling. After negotiating a curve, the steering servos quickly bring the steering wheel back into the starting position and you quickly return to ideal straight-ahead driving.

Differential lock



The high-quality disc differential locks in both axles are sensitively controlled via sensors, dependent on steering angle and speed. The locks are actuated without troublesome tension in the drive train. In conjunction with the automatic 4WD control, this provides you with superior pulling power and ride comfort.

Wheelbase



The 2,420 mm wheelbase provides stability and an optimal weight distribution.

Fendt Reaction steering system



 Fendt Reaction steering system ensures optimal straight-ahead driving at fast speeds on the road.

Driving dynamics with safety and comfort

- 40 km/h transport speed at reduced engine speed (1,700 rpm)
- Permissible overall weight of up to 8.5 tons
- High payload of more than 3.5 tonnes
- Self-levelling front axle suspension with longitudinal arm for best ride comfort
- 100% disc locking differential for front and rear for best power transmission
- Fendt Reaction steering system for better straight-ahead driving at fast speeds on the road
- Automatic modes for 4WD and differential lock
- Smart brake light actuation for early warning when decelerating
- Automatic trailer steering axle lock for comfort and safety

Mounting areas at the front and rear

Yes. It can.

Strong front linkage, precise electric adjustment, high-volume hydraulics, front and rear PTO, numerous mechanical or electric valves, ISOBUS and power beyond – the Fendt 300 Vario is multivariable and offers a number of interfaces for the mounting areas. The Fendt 300 Vario guarantees you maximum versatility when working with implements.



“What I especially like about the Fendt 300 Vario is that it is as comfortable as my sofa. And, of course, that it has so many practical features, such as the external controls for the linkage or the actuation of the control valves.”

Licia Cocozzella, contractor and Fendt driver from Italy



Full function for front.

Powerful lifting

The stable half-frame construction of the Fendt 300 Vario permits powerful front linkage with a 3,130 daN lift capacity. If the front linkage is not required, it can be disabled using the shut-off cock. The lower links are foldable – practical for the park position or for front loader work. The Fendt 300 Vario Profi has a switchover stop cock for fast changes between sa/da without unplugging and plugging. The Profi version also has external controls for easy mounting and removing of front-mounted implements.

Powerful hydraulics

With a 110-litre delivery volume, the load-sensing pump (LS control pump) has a high volume capacity. This pump capacity permits the engine speed to be kept low, which saves fuel effectively, even during demanding operations. The Fendt 300 Vario is equipped with the powerful 110-litre LS control pump as standard in the Profi equipment level. The Power variant has an 84-liter constant flow pump as standard and can be equipped with the 110-litre pump.



Reliable duo: In both the Power and Profi equipment lines, the Fendt 300 Vario offers you the best solution for your individual requirements as well as diverse functions and mounting areas in the front: top link, double-acting control valves and unpressurised return, 7-pin socket, front PTO (1000 rpm), front linkage with electrohydraulic control (Profi), lower link catch hooks, foldable lower links, shut-off cock;

Front mounting areas



The front linkage is fully integrated in the half-frame and therefore especially stable. The lower links on the front linkage can be folded up diagonally - which provides more free space for front loader work.



The new integrated front PTO delivers 1000 rpm. The direct drive line from the engine to the implement means high efficiency.

Three front linkage types available

The Fendt 300 Vario offers three front linkage variants. In addition to the normal front linkage, there is also a version with position control as well as one with position control and load relief control. All versions have vibration damping and anti-twist protection on the lower link bearing pins.

Relief during operation

The comfort front linkage has optional load relief control, which can be adjusted using the Varioterminal. It uses the double-acting front linkage valve to lower the implement and transfers the weight of the implement to the front axle. Mower relief springs are no longer necessary. This means perfect ground hugging, especially high traction and gentle handling of the sward in the grassland operations.

Load relief front linkage control

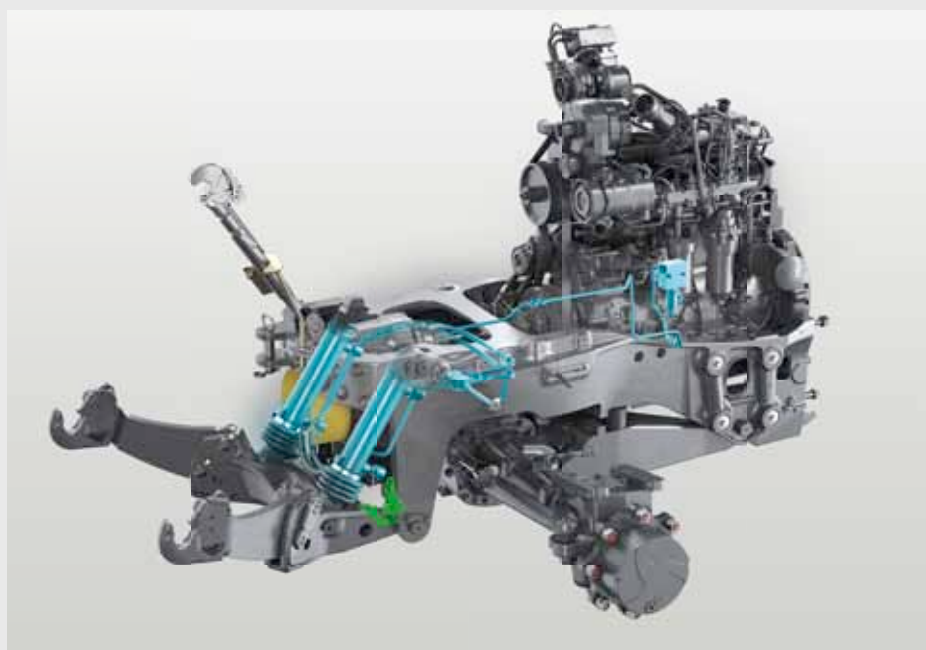

 The load relief front linkage control is a special advantage for operations with a front mower in grassland, with front mulching implements, as well as with a snow plough, since the implement adapts to uneven ground very quickly.

Thousands of ideas for rear-mounted implements

Function and overview at the rear

At the rear, the Fendt 300 Vario shows what it's made of. All functional elements, such as hydraulic couplings, PTO and rear linkage, are clearly laid out and easy to access. The Fendt 300 Vario is equipped with up to four control valves. The Power version has mechanical valves with flow volume control on the 1st and 3rd valves. The Profi version has freely assignable valves and offers a time function for flow control, which can be easily adjusted using the Varioterminal.

More power with power beyond

The power beyond connection comprises a pressure line, a control line and a return for hydraulic oil. The control line regulates the output of the hydraulic pump dependent on the oil requirement of the implement. The line has an especially high flow for high hydraulic oil volumes. The oil is transported directly to where it is needed, quickly and without power losses.



All the interfaces at the rear are arranged functionally and clearly. Signal socket, hydraulic top link, spool valves, unpressurised return, compressed air brake, pressure and control line power beyond, hydraulic trailer brake, 7-pin socket, lower link catch hooks, hitch, rear PTO 540, 540 E and 1000 rpm, bottom hitch, rigid drawbar and much more.

Duomatic coupling at rear

Fast coupling and uncoupling made easy: The Duomatic coupling permits compressed air connections from trailers to be coupled and uncoupled with just one hand movement.

Separate oil supplies for transmission and hydraulics

The separate oil supplies prevent oil mixing and guarantee high operational reliability of the transmission.

The right speed ...

... for the PTO shafts can be easily adjusted using the keys on the Variocentre: the speeds 540, 540 E and 1000 rpm are available for the rear PTO. Practical are the external controls on the rear mudguard. The Eco variant 540E is ideal for light work, where fuel can be saved at a reduced engine speed. The PTO shafts on the Fendt 300 Vario have outstanding efficiency, since power to the PTO stub flows through a direct drive line from the Vario transmission.

PowerBeyond



Power beyond pressure and control line for full hydraulic power transmission

External controls rear linkage



➤ The valves in the Profi version can also be operated externally on the rear mudguard, an advantage when mounting implements.

ISOBUS socket



Connection for the ISOBUS implement control.

Rigid drawbar



➤ The lower links can be fixed in place through a shut-off cock on the rear linkage, so they cannot move upwards.

DCUP/CUP couplings



➤ Both the DCUP and CUP couplings permit the hydraulic valves to be coupled under pressure and mounting and removing implements is easy. The self-closing valve flaps offer secure protection against contamination through dirt or water.

Automatic steering axle lock



➤ The optional automatic steering axle lock automatically unlocks the steering axle at a predefined speed on trailers with self-steering axles. On straight stretches, the locked self-steering axle ensures stable handling. Operators do not need to lock the self-steering axle manually outside of the preselected speed range and when reversing.

Loading under control.

Extend your tractor

The Fendt 300 Vario is the perfect tractor for loader work. Its compact design and the large steering angle permit agile driving. Loading work can be monitored completely through the panoramic windscreen of the VisioPlus cab – even when the front loader is fully raised. High hydraulic capacities ensure fast lifting movements and precise loader response, even at low engine speeds. You can operate the front loader easily with the crossgate lever. Your left hand remains free for steering and reversing. You control the speed

with your foot. The Cargo front loader is available in four versions: Cargo 3X70, 4X75, 4X75 compact and CargoProfi 4X75. In the compact version of the 4X75, the arm is attached 100 mm closer to the cab. This makes the tractor even more stable during front loader work. You decide which Cargo is the best for you according to the functions you need.



Fendt 300 Vario with Fendt Cargo 4X75 compact front loader

Precise loading

Thanks to the precise measuring and tilt sensor system on the CargoProfi 4X75, you know exactly how much you are loading. Weigh your load with the touch of a button and utilise the full loading capacity. You do not need to drive to the weighing station anymore and you can monitor the quantity of your loads better. You can set the exact working height and tipping angle precisely with the CargoProfi. Your bucket is emptied completely thanks to the integrated shake function, which loosens loaded material that sticks. The Memo

function saves positions and makes frequently repeating jobs easier. You will find detailed information on front loader operations in the Fendt Cargo brochure.

Torsion-resistant arm for rugged jobs

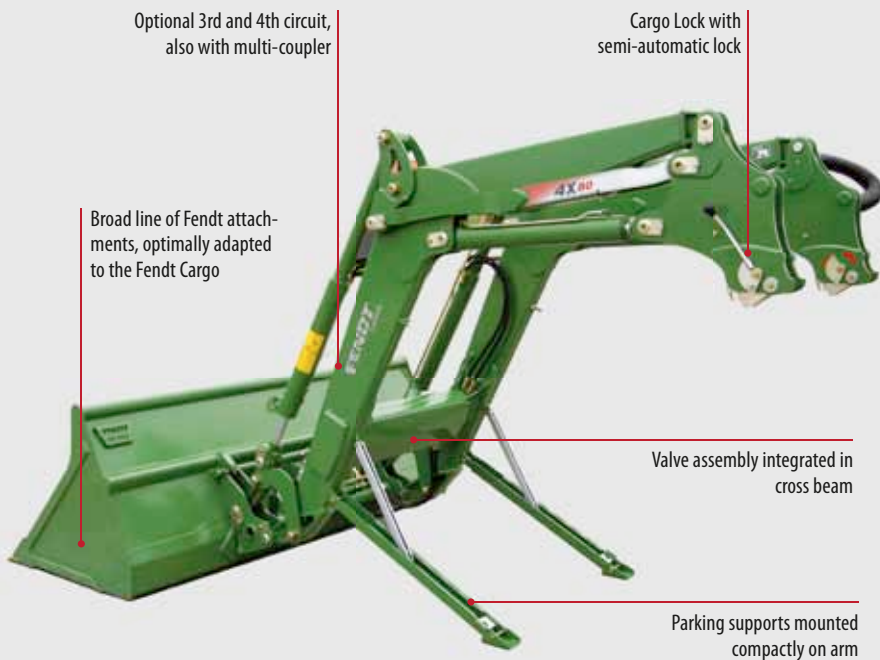

Fendt CargoProfi

- Settings integrated in the Varioterminal
- Weighing function: Loads are weighed with the push of a button, both individual and total weight possible
- Working range, such as lifting height and tilt angle, can be limited
- Memo function: Save positions for arm and attachment
- End position damping
- Shake function
- Speed-dependent damping (automatic enabling and disabling)

Model		3X/70 ²⁾	4X/75	4X/75 compact	4X/75 profi
A	Digging depth (mm) ¹⁾	150	150	220	150
B	Lifting height (mm) ¹⁾	4155	4155	4085	4155
C	Dumping distance (mm) ¹⁾ B = 3.5 m	1685	1685	1585	1685
C	Dumping distance (mm) ¹⁾ B = max.	1145	1145	1045	1145
D	Angle of emptying	55°	55°	55°	55°
E	Angle of backwards tilt	48°	48°	48°	48°
	Lift capacity over full height (daN)	1940	2260	2260	2260
	Max. lift capacity (daN)	2250	2620	2620	2620

¹⁾ Depends on tyres
²⁾ Max. tyre size 480/65R24 (max. diameter 1,260 mm)

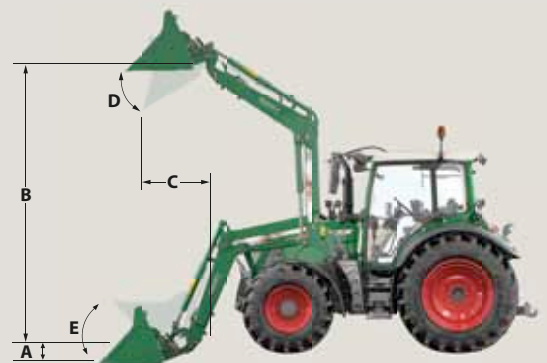



Simply convincing.

The Fendt 300 Vario unites efficient technology and sophisticated solutions to help you master all daily challenges. Flexible, agile and reliable, it stands at your side during all operations. With the stepless Vario transmission and the comfortable cab, you get the unique Fendt driving experience – Leaders drive Fendt.



1. Front axle with 52° swing angle
2. Front power lift with external actuation (Profi)
3. Front PTO
4. Planetary final drive
5. 4.4 l AGCO Power engine with 4 valves per cylinder
6. Cooler unit
7. SCR catalytic converter
8. Stepless Vario transmission
9. Hydro motor
10. Hydraulic pump
11. Enclosed 4WD clutch (handbrake)
12. Fuel tank with 210-l capacity
13. AdBlue® tank with 23-l capacity
14. Rear PTO
15. Rear axle
16. LED work lights (option)
17. Rear linkage
18. VisioPlus cab with integral climate control and nearly 6 m² of glazing
19. Pneumatic cab suspension
20. Variocentre
21. Varioterminal 7-A
22. Air-suspended super comfort seat, seat heater, pneumatic lumbar support and rotary adapter
23. Comfort passenger seat with automatic seat belt
24. Wide-angle mirror, electrically adjustable, heated (Profi)
25. External rear controls for linkage, PTO and one hydraulic control unit (Profi)

Model versions

Fendt 300 Vario Power version



Fendt 300 Vario Profi version



**MACHINE
OF THE YEAR 2015**

Technical Specifications

Fendt	310	311	312	313
Engine				
Rated power ECE R 24 (kW/hp)	69 / 93	78 / 107	85 / 116	92 / 126
Maximum power ECE R 24 (kW/hp)	81 / 110	88 / 119	95 / 129	102 / 138
Rated power EC 97 / 68 ¹⁾ (kW/hp)	74 / 100	83 / 113	90 / 123	97 / 133
Maximum power EC 97 / 68 ¹⁾	83 / 113	91 / 123	98 / 133	105 / 142
No. of cylinders/cooling	4/water	4/water	4/water	4/water
Cylinder bore/stroke (mm)	108 / 120	108 / 120	108 / 120	108 / 120
Cubic capacity (cm ³)	4400	4400	4400	4400
Rated engine speed (rpm)	2100	2100	2100	2100
Engine speed at max. power (rpm)	1750	1750	1750	1750
Optim. fuel consumption (g/kWh)	199	199	199	199
Max. torque 1550 rpm (Nm)	485	524	559	596
Torque rise (%)	55	47	44	42
Fuel tank (l)	210	210	210	210
AdBlue® (l)	23	23	23	23
Oil change interval operating hrs	500	500	500	500

Transmission/PTO				
Continuously variable Vario transmission ML 75	40 km/h	40 km/h	40 km/h	40 km/h
Speed range: (forward / reverse)	0.02 to 40 km/h / 0.02 to 25 km/h			
Front PTO (rpm)	1000			
Rear PTO (rpm) standard	540 / 540E / 1000			
Rear PTO (rpm) option	540 / 1000 / ground PTO (4.5 rev/driven metre 540/65R34)			

Hydraulics				
Type	Electrohydraulic power lift control with shock load stabilising			
Control	Free floating, position, draft and inf. adj. mix control			
Hydraulic pump capacity (l/min)	Tandem pump (46+38 l) total 84 l/min or load sensing system with control pump 110 l/min			
Working pressure (bar)	200	200	200	200
Auxiliary control valves standard / max.	2 / 4	2 / 4	2 / 4	2 / 4
Max. available oil volume (l)	43	43	43	43
Flow volume, spool valves (Power)	1st valve: 15-65 litres, 2nd and 4th valves: up to 80 litres, 3rd valve with 15-70 litres			
Max. lift capacity, rear linkage (daN)	5960	5960	5960	5960
Max. lift capacity, front linkage (daN)	3130	3130	3130	3130

Brakes				
Rear brakes	Wet ring piston brake			
Four-wheel brake	Automatic 4WD engagement			

Weights and dimensions				
Unladen weight with cab (kg)	4810	4810	4970	4970
Max. perm. overall weight (kg)	8500	8500	8500	8500
Max. perm. front axle load (kg)	4500 (at 8 km/h: 7500)			
Max. perm. rear axle load (kg)	7000	7000	7000	7000
Max. hitch load (kg)	2000	2000	2000	2000
Overall length (mm)	4336	4336	4336	4336
Overall width (mm)	2220	2220	2320	2320
Wheelbase (mm)	2420	2420	2420	2420
Overall height comfort cab (mm)	2820	2820	2860	2860
Distance from centre of axle to upper edge of cab (mm)	2058	2058	2058	2058
Ground clearance with max. tyres (mm)	510	510	510	510
Standard track front (mm)	1685	1685	1820	1820
Standard track rear (mm)	1660	1660	1800	1800

Electrical equipment				
Alternator	14 V / 150 A			
Battery	100 Ah / 12 V			

Tyres				
Standard front	440/65R24	440/65R24	480/65R24	480/65R24
Standard rear	540/65R34	540/65R34	540/65R38	540/65R38
Optional front	480/65R24	480/65R24	16.9R24	16.9R24
Optional rear	540/65R38	540/65R38	18.4R38	18.4R38
Optional front	540/65R24	540/65R24	540/65R24	540/65R24
Optional rear	600/65R38	600/65R38	600/65R38	600/65R38

Equipment levels	Power	Profi
Vario controls		
Vario joystick with 2x cruise control, 1x engine speed memory, automated functions rear	●	
Multi-function joystick with 2x cruise control, 2x engine speed memory, automatic functions, controls for hydraulics		●
Varioterminal 7-A with key control		●
Variotronic implement control (ISOBUS)		□
Variotronic ²¹ Headland Management System		●
Vario TMS Tractor Management System	●	●

Cab	Power	Profi
One-piece windscreen	●	●
One-piece windscreen and door on right	□	□
Split windscreen and door on right	□	□
Mechanical cab suspension	□	●
Pneumatic cab suspension		□
Height and tilt-adjustable steering column	●	●
Comfort seat, air suspended with back rest (w/o rotary adapter/seat cushion adjustment, armrest adjustment right)	●	●
Super comfort seat with seat heater, lumbar support, rotary adapter, seat cushion adjustment, armrest adjustment on both sides	□	□
Passenger seat with automatic seat belt	●	●
Radio mounting kit with 2 stereo speakers	●	●
Radio CD MP3 Blaupunkt with 2 stereo speakers	□	□
4 stereo speakers		□
Air-conditioning	●	●
Automatic climate control		□
Pollutant filter (aerosol)	●	●
Segment wipers front	●	●
Parallel wipers front	□	□
Rear window heated	□	□
Ext. rearview mirror, mechanically adjustable	●	●
Ext. rearview mirror, electrically adjustable, heated		□
Ext. rearview mirror and wide-angle mirror mechanically adjustable	□	
Ext. rearview mirror electrically adjustable and wide-angle mirror heated		□
Interior rearview mirror		●
Work lights roof, 4 rear, 2 front	□	●
Work lights A-pillar, roof front, mudguard rear	□	□
Work light LED A-pillar, mudguard rear	□	□
Ambient lighting	●	●
Bracket for auxiliary devices	□	□
Cooling compartment	●	●
Electric battery disconnect switch	□	□
Add. Additional storage space, light in roof liner left		●

Engine / Transmission	Power	Profi
Preheater unit (engine, transmission oil)	□	□
Shuttle function, stop-and-go function	●	●
Acoustic signal when reversing		□

Chassis / safety features	Power	Profi
Compressed air system 1-/2-line system	□	□
Automatic trailer steering axle lock		□
Compressed air Duomatic coupling	□	□

4WD / differential locks	Power	Profi
Comfort engagement controls for 4WD / differential locks	●	●
Rear / front differential with 100% disc locking and steering angle sensors	□	●

Equipment levels	Power	Profi
Power shift PTOs		
Rear PTO (540/540E/1,000 rpm)	●	●
Flanged PTO (540/540E/1,000 rpm)	□	□
Rear PTO (540/ground PTO /1,000 rpm)	□	□
Front: 1,000 rpm	□	□
External controls for rear PTO	●	●

Hydraulics	Power	Profi
Load-sensing system with 110 l/min delivery capacity	□	●
Electrohydraulic rear linkage sa (EPC)	●	●
1st and 2nd hydraulic valve at rear	●	●
1st hydraulic valve middle and rear	●	●
3rd hydraulic valve at rear	□	□
3rd valve middle and rear	□	
3rd valve middle (instead of 3rd valve rear)		□
4th valve rear	□	□
Return rear	●	●
Return middle right	●	●
Unpressurised return rear (case drain)	□	□
Hydraulic power beyond connection	□	□
Hydraulic valve actuation crossgate lever (Power mechanical, Profi electric), CUP couplings rear	●	●
DCUP couplings in rear (1st – 4th valve)	□	□
Top link rear hydraulic	□	□
Front linkage sa/da (connection middle 1st / 3rd valve)	□	□
Comfort front linkage sa/da, external controls (separate valve)		□
Comfort front linkage sa/da, with position control (EHR), external controls (separate valve)		□
Comfort front linkage sa/da, with position control (EHR) and load relief control, as well as external controls (separate valve)		□

Body	Power	Profi
Mechanical hitch	●	●
Auto. hitch with remote control, rear	□	□
Ball-type coupling, height adjustable	□	□
Ball-type coupling in the bottom hitch	□	□
Hitch	□	□
Swinging drawbar	□	□
PitonFix	□	□
Rotating beacon left and right	□	□
Pivoting front wheel mudguard	□	●
Front weights, various sizes	□	□
Ballast weights for rear wheels	□	□

Front loader	Power	Profi
Front loader attachment parts	□	□
Front loader Cargo 3X/70	□	□
Front loader Cargo 4X/75	□	□
Front loader Cargo 4X/75 compact	□	□
Front loader Cargo 4X/75 profi		□

Leaders drive Fendt.

You must experience for yourself the ingenuity of the Fendt Vario down to the very last detail. Test a Fendt, convince yourself and make the right investment.



Invest in profitability

Overall profitability distinguishes the entire product line of the premium brand Fendt. The efficiency of the products guarantees the best cost-effectiveness per hectare. In combination with the extremely high retention of value of a Fendt, you also get an unbeatable resale value at the end of your tractor's service life. As a trendsetter, Fendt continually sets important new standards and installs technology that continues to be in demand in the future. Add to that the high quality, which ensures operational reliability and a long life. The total is a retention of value that only Fendt can offer you.



Certified quality

We achieve a constant, excellent premium quality through first-class workmanship and use high-grade materials for all components. In the development phase, the tractors undergo comprehensive testing, with up to 10,000 engine hours under the toughest conditions, to thoroughly test the durability of components. In series production, Fendt relies on comprehensive testing processes to ensure that each individual tractor leaves the factory with the highest quality.



We offer more – join us!

Fendt not only offers high-quality products with cutting-edge technology, but also assists you in getting the most out of your Vario. With the help of our Fendt driver training Fendt Expert, you can further optimise profitability and learn to make all the settings and adjustments to drive at an absolute optimum in different operations.



More freedom for investments

Tailor-made financing from AGCO FINANCE and the customised service package: A custom financing package with attractive conditions and flexible terms offers you an ideal opportunity to match your investment to the needs of your farm or business. With a Fendt Service Package, you also have servicing and repair costs under control. When purchasing your tractor, you can already plan the prescribed service work based on attractive fixed prices – with the Service or comprehensive ProService package.

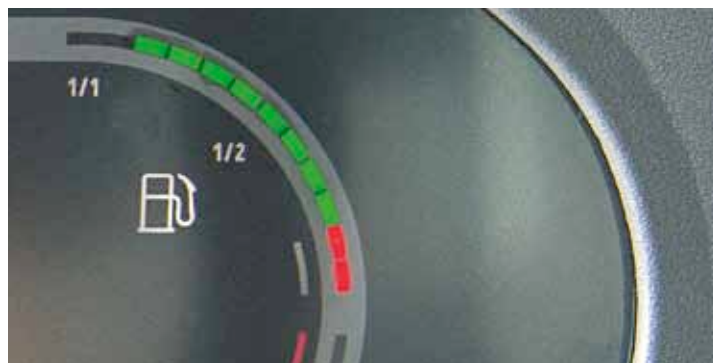

Efficiency – for our customers' success

Efficiency is the recipe for successful financial management in agriculture. We make no compromises when it comes to efficiency, because our objective is to be the leader for cost-effectiveness per hectare and kilometre. Then the best technology is just enough, technology like that which we build into the tractor: for example, the highly efficient Vario drive train and the fuel-saving emissions technologies in combination with TMS.

FENDT

Leaders drive Fendt



**MACHINE
OF THE YEAR 2015**

www.fendt.com

AGCO GmbH – Fendt-Marketing
87616 Marktoberdorf, Germany

Sales agent:

Your Agriculture Company

Fendt is a worldwide brand of AGCO.

All data regarding delivery, appearance, performance, dimensions and weight, fuel consumption and running costs of the vehicles correspond with the latest information available at the time of going to press. Changes may be made before the time of purchase. Your Fendt dealer will be pleased to supply you with up-to-date information.