

FENDT

Fendt 200 Vario V/F/P







Simply. Top notch.

Since the introduction of the 200 Vario V/F/P series, Fendt has set standards for absolute top technology in the area of specialty tractors. Experience the highest efficiency and productivity, as well as outstanding ride comfort, for wine, fruit and hops production with Fendt.

Three times top

The smallest Fendt is strong in all areas. Depending on the variant, it has special specifications:

Fendt 200 Vario V

For wine-growing, Fendt offers the classic narrow track tractor:

- For spacings from 1.50 m to 2.20 m
- Narrow dimensions starting at an outer width of 1.07m
- Alternative: V with wide front axle for optimum manoeuvrability



Top for wine,
fruit and hops.

	kW	HP
Fendt 207 Vario V/F	51	70
Fendt 208 Vario V/F	59	80
Fendt 209 Vario V/F/P	67	90
Fendt 210 Vario V/F/P	73	100
Fendt 211 Vario V/F/P	81	110

Maximum output to ECE R24



Fendt 200 Vario F

The ideal tractor for fruit and wine-growing:

- For wide spacings with distance between rows from 1.90 m to 3.00 m.
- Outer width starting at 1.32m
- Vegetable growing and hothouse operations

Fendt 200 Vario P

The specialty tractor for hops and fruit-growing:

- Row widths from 2.20 m to 5 m
- Outer width starting at 1.68 m
- Comfortable, wide cab

Unbeatable manoeuvrability

The high-quality front axle design unites surprising manoeuvrability and robustness with excellent handling. A 58 degree steering angle, wasp-waist design, three degree castor angle and the robust planetary final drives with excellent payload capacity, build the basis for high performance. It is therefore easy to change over to the next row at the end of the row.

CUTTING-EDGE ENGINE AND TRANSMISSION TECHNOLOGY

Top CVT.

Powerful to the top

The Fendt 200 Vario V/F/P is equipped with the 3-cylinder AGCO Power engine. It is a lively and dynamic engine that runs smoothly and delivers a high output. During development, the focus was on optimising application in practice. This allows you to work fuel efficiently in row crops. The maximum speed of 40 km/h is attained at a low 1,750 rpm.

Efficiency for top performance

The savings potential of the continuously variable transmission is clearly noticeable. You save valuable working time – up to ten percent – through higher area coverage and also profit from low fuel consumption. The Tractor Management System (TMS) keeps the engine running at an economical optimum. And driving the tractor, either with the joystick or pedal, is always a relaxed matter.

All the way to the top without gear steps

Nothing drives like the continuously variable Fendt Vario transmission. Because Fendt Vario stands for stepless, dynamic driving with plenty of torque. With the Fendt 200 Vario V/F/P, you can work at any speed precisely from 0.02 km/h to 40 km/h and achieve additional power that cannot be achieved with manual transmissions. The speed can be adapted to the requirements without jerking and without interruption of power, even on slopes.

The Vario transmission on the Fendt 200 Vario V/F/P was especially adapted to the smaller size of the tractors and its special needs. The Vario transmission has proven itself for the requirements of specialty tractors and offers tremendous benefits.



Engine characteristics – Fendt 211 Vario V/F/P

458 Nm torque, 110 hp/81 kW maximum output at 1,900 rpm.

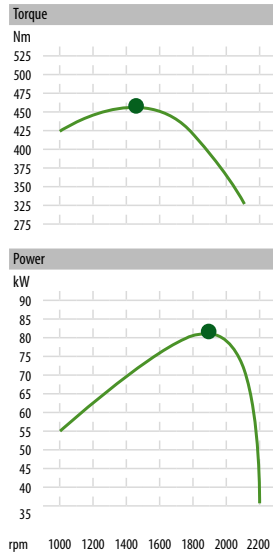

The external EGR system provides targeted cooling of recirculated exhaust, which substantially lowers fuel consumption compared with internal exhaust gas recirculation systems.



The efficient cooling system on the Fendt 200 Vario V/F/P has large intake areas. This results in less dirt in the radiator and optimised cooling performance, even during extreme operating conditions. The air filter features a cyclone precleaner, which guarantees a long filter life and less maintenance work. Despite the small installation space, it has a high air output.



The tractor management system TMS controls the engine and transmission so that they are always working at an economical optimum without you having to think about it. You just have to specify the desired speed.

THE COMFORT CAB

Ergonomics for top performance.

Top ergonomics

When developing the Fendt 200 Vario V/F/P, special emphasis was placed on the ergonomic design of the operator environment. The cab offers a large amount of legroom, since there is no transmission tunnel. On the right is the central control unit for all tractor and implement settings. The height and tilt-adjustable steering wheel offers exceptional operating ergonomics.

Perfect work environment

The efficient heating and ventilation system with integral manual or automatic air-conditioning ensures an optimum working environment. The hot water heating, which uses the water cooler, ensures a comfortable temperature in the cab, even on cold days. The roof window provides pleasant fresh air.

Best visibility in all directions

The generous glass areas, the narrow steering column and the roof window provide an optimum view to the implements at all times. The ambient interior lighting gives you an excellent overview, even at night, allowing targeted control of all functions.

Quiet cab

The cab has conical bearings and is isolated from the tractor body, which keeps the noise level very low. The extremely well insulated cab and the water-cooled engine, which is extremely smooth-running at low engine speeds, ensure optimum noise reduction.

If height is decisive: the low roof

All three variants can be optionally equipped with a low roof. This decreases vehicle height by 15 cm. Just as in the normal version, these tractors have both a heating and ventilation system. With standard tyres, the low roof version of the Vario V has a vehicle height of 2.21 metres and the Vario F version only 2.29 metres.



The flat cab floor on the Fendt 200 Vario V/F/P provides unprecedented legroom and makes climbing in and out easy. Another factor that increases legroom is that there are no operating elements in the foot well to get in the way.

The automatic climate control provides optimum temperatures in the cab.

The cab on the Fendt 200 Vario has hot water heating and can also be equipped with perfectly integrated air-conditioning. Automatic climate control is available as an option.



The practical arrangement and colour coding of the operating elements guarantee continuous, fast and logical operation.

The fold-down safety frame enables work in areas where a very low vehicle height is required. Even without a cab, you have a flat floor for easy climbing in and out and an optimal leg position. Exceptional visibility means you always have the implement in perfect view.

THE CONTROLS ON FENDT 200 VARIO V/F/P

Operating and driving comfort the finest.

Pleasant workplace

Perfectly arranged operating elements as well as an ergonomically designed driver station make work significantly more effective and easier. That is why a centralised operating unit with integral armrest, located on the right-hand side, was developed for all the 200 Vario V/F/P models. The optional Profi package is also available to meet further requirements.

Vario joystick – functions that make work easier

The standard version is ideally suited for anyone who, due to their area of application, is looking for a simple and easy solution for operation. At the core of the control concept is the Vario joystick which is optimally adapted to the continuously variable transmission. It controls the transmission and cruise control, activates the engine speed memory and actuates the 3rd and 4th hydraulic circuits.

For demanding users: the Profi package

The Profi package leaves no wishes open and offers extensive application options for professional operations. This enhanced equipment level includes additional control valve functions and automated functions for the rear linkage and rear PTO, which can be controlled with the multi-function joystick. In addition to TMS, the Profi package includes an integral reversing lever on the left of the steering column as standard. Control of up to six control units is possible.

Sensitive controls

The crossgate lever permits sensitive control of the first and second control valves. The third to fifth valves are controlled with three linear modules, which are conveniently located in front of the armrest. The PTO controls also lie well within reach. A membrane keypad is used to engage and disengage the PTO and enable the PTO automatic mode.

 You have everything under control with the buttons on the comfortable multi-function joystick: Rear linkage, control valves, cruise control and engine speed memory



 In the standard version, the Fendt 200 Vario V/F/P is controlled with the Vario joystick. It has controls for the 3rd and 4th hydraulic circuits, the engine speed memory key and the cruise control memory key.



The armrest folds up to expose a rotary control that selects the button assignment for the multi-function joystick. The oil flow volume of the individual valves can be set with the rotary controls.



The 3rd and 5th control units can be actuated with the three linear modules on the armrest.

On the dashboard, you can quickly and easily operate the multiple display, comfort engagement for 4WD, differential lock and front axle suspension as well as the Tractor Management System TMS.

The clearly laid out instrument cluster has a speed display with cruise control, rpm display and multi-display.

ECONOMICAL IMPLEMENT COMBINATIONS

Perfect mounting areas.

Everything fits together here

The Fendt 200 Vario V/F/P offers three mounting areas: the front, middle and rear mounting areas. It is therefore ideally suited for operations with economical implement combinations. These not only save operating time and machine costs, but also increase working quality by reducing driving tracks and soil compaction.

Efficient hydraulics

Modern implements demand ever greater flexibility and performance from the tractor hydraulics. Fast lifting and high oil delivery rates are required for economical and precise operation. The Fendt 200 Vario V/F/P meets all the demands on the hydraulic system. With the high-tech hydraulic system from Fendt, implements that have many hydraulic functions, for example a leaf cutter, can be controlled easily and comfortably.

Powerful hydraulics

The Fendt 200 Vario V/F/P is equipped with a load sensing hydraulic system. Modern axial piston pumps deliver the exact quantity of hydraulic oil required – up to 76 litres per minute (with summation 106 l/min). A maximum of 25 litres of hydraulic oil is available to mounted or trailed implements. The oil supplies for the transmission and hydraulics are separate. Bio-oils can always be used for the hydraulics.

Auxiliary valve equipment for all cases

In the Profi package, the Fendt 200 Vario V/F/P has four electric double-acting auxiliary valves as standard specification and can be optionally equipped with up to six valves. These are controlled with the crossgate lever, linear modules and the multi-function joystick.

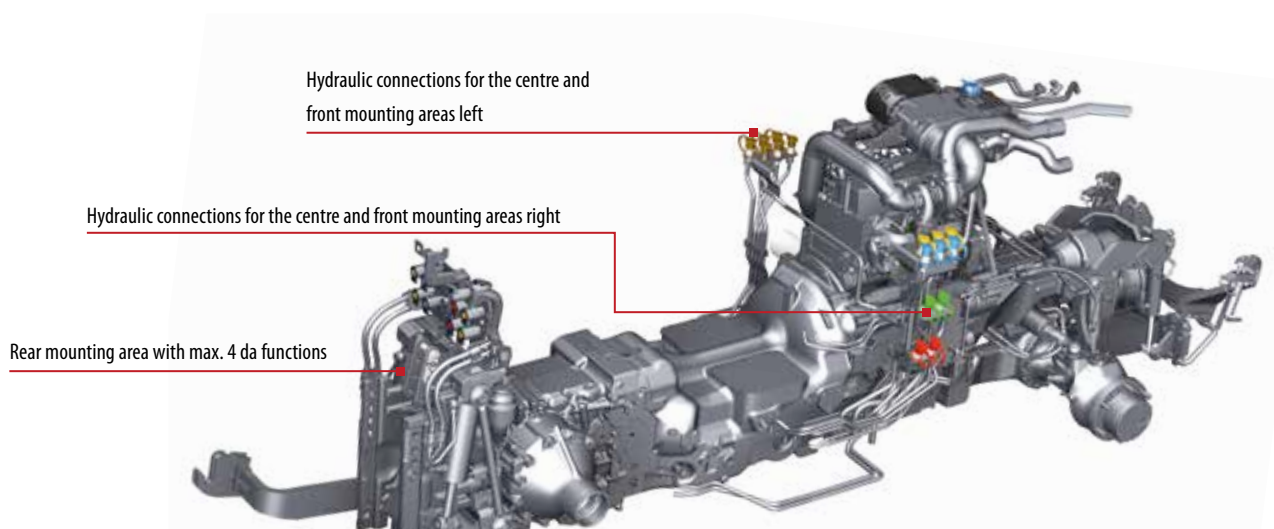

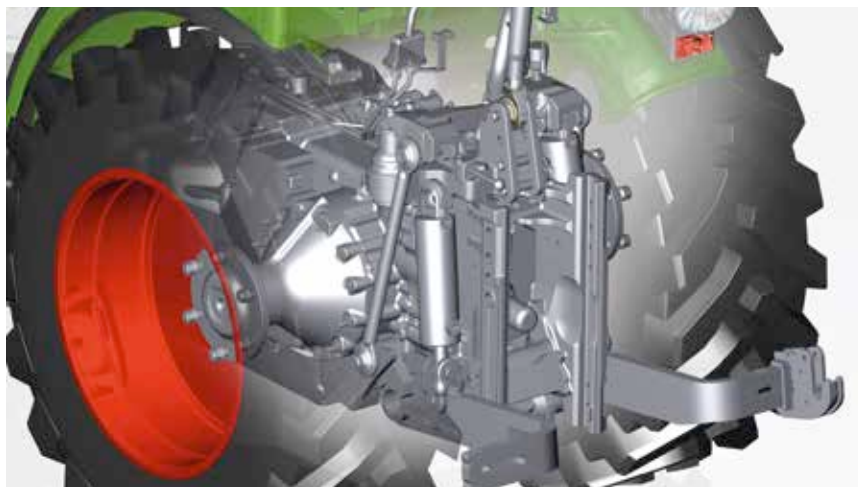

The electro-hydraulic rear linkage, with a maximum lift capacity of 2,715 daN (200 Vario V), guarantees that rear implements can be lifted over the full height without trouble. The standard-equipped shock load stabilising system counteracts vehicle bounce by actively lifting and lowering the power lift.

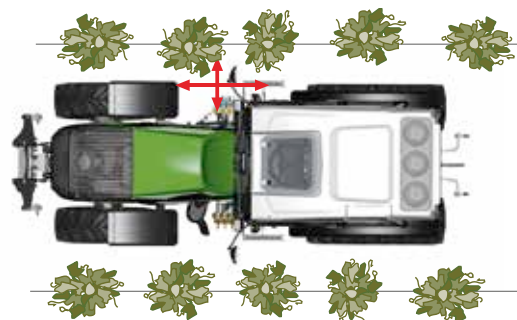

 You can control the lateral and tilt adjustment of the swinging power lift, as well as swing and lock, with the push of a button. You can monitor tilt with the tilt control indicator in the cab.

 The crossgate lever controls the 1st and 2nd valves sensitively. The 3rd and 4th hydraulic circuits are controlled with the buttons on the crossgate lever.



 **Efficient thanks to mid-mount area**
A large 45-cm wide clearance permits excellent visual monitoring of implements. Four double-acting valves on the right-hand and two valves on the left-hand side, together with return flow and cross connection, permit optimal control of high-level hydraulic combinations. You can operate time and cost-saving implement combinations in three mounting areas simultaneously.

THE VEHICLE DESIGN CONCEPT

Manoeuvrable, stable, safe – simply top notch.

Power on all wheels

In addition to the permanent 4WD, the Fendt 200 Vario V/F/P also has automated 4WD. Both can be engaged and disengaged with the push of a button. The automated 4WD regulates 4WD engagement fully automatically, dependent on steering angle and speed. This guarantees full manoeuvrability at all times, reduces tyre wear and lowers the operator's workload.

Sensitive high-performance brake

The practically maintenance-free four-wheel braking system ensures superb driving safety on slopes and on the road. It comprises two integrated multi-disc brakes for the rear wheels and a multi-disc pack for the 4WD engagement on the front wheels. The brakes are automatically sprayed with fresh oil every time they are actuated, which reduces thermal loads to a minimum.

High-quality multi-disc differential locks

Through the use of high-quality 100 percent locking differentials at the front and rear (V and F), the locks can be fully engaged and disengaged under load. The locks release immediately when disengaged. The P-tractor has the tried and proven Locomatic self-locking differential in the front axle. If you switch off the engine while the 4WD and differential locks are engaged, these functions are automatically fully reactivated later, when the tractor is restarted - this increases safety on slopes.

Exceptional ride and operating comfort

The intelligent combination of three systems guarantees maximum ride and operating comfort: the self-levelling front axle suspension with anti-roll control, the cab on silent bearings and the active shock load stabilising. The suspension reliably minimises shock loads and counteracts uneven ground on the road and in the field – by up to 20 percent. Self-levelling permits high payloads and ensures a constant, high degree of suspension comfort even with high loads.



Front axle suspension design

- Hydropneumatic, self-levelling suspension with hydraulic cylinders, swing arm, nitrogen reservoirs and lateral stabiliser
- Functions: suspension, level control, lock and anti-roll control
- Activation and control via electronics and independent hydraulic manifold
- Up to 6 electric valves are possible with suspension



➡ The secret of the exceptional climbing capability lies in the swinging power lift (V/F tractors) and the tractive point that lies in front of the rear axle. With increasing traction requirement, the weight that is transferred to the front axle is also increased. That enables high traction and climbing capability with minimum slip.

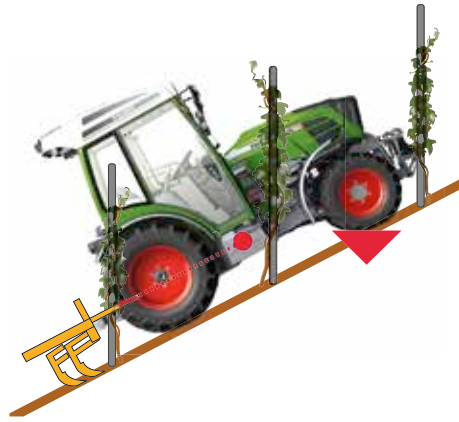

The smallest turning radius is just 3.2 metres, depending on the tyres. You will notice this immediately at the end of the row, where you can switch to the row after the next without having to change direction.

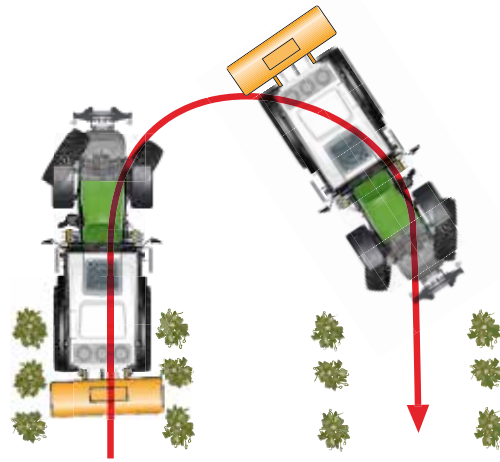

➡ The narrow wasp-waist design enables a wide steering angle of up to 58°, which means outstanding manoeuvrability.



The self-levelling front axle suspension on the Fendt 200 Vario V/F/P specialty tractor guarantees maximum ride comfort, best driving safety and optimum traction. This provides considerable advantages on steep slopes, since all four wheels are in contact with the ground longer.



When cutting leaves, the suspension with anti-roll control dampens uneven ground reliability and sensibly with FSC. It ensures that working height and lateral tilt remain constant. Advantage for the driver: calm, relaxed work, because constant adjustments are not needed.



Even when driving fast on the road, the Fendt 200 Vario V/F/P provides high ride comfort, even with mounted implements. Driving safety is very high, because bouncing is prevented.

THE FENDT OVERALL PROFITABILITY

Invest right – and keep on saving.



It is clear that you get cutting-edge technology with a Fendt tractor. However, there is much more to the overall cost picture of a Fendt tractor: from competent consultation, to comprehensive services up to the exceptional value retention of a Fendt tractor.

Fendt overall profitability

- Fendt Efficiency for the best cost-effectiveness per hectare
- Fendt Comfort for pleasant working conditions day after day
- Fendt Retention of Value for an unbeatable resale value
- Fendt Service for competent consultation and full reliability
- Fendt Flexibility for custom financing and individual offers
- Fendt Expert Driver Training for highly efficient Vario driving

Performance and profitability under contract

A Fendt StarService contract gives you full cost control with the best service. The Fendt service package includes all the prescribed maintenance work based on attractive fixed prices. The ProService package includes regular maintenance and repairs in combination with an extended warranty of up to 6,000 total operating hours or up to five years.

100% quality, 100% service: Fendt StarService

To ensure that your Fendt 200 Vario V/F/P delivers 100 percent performance at all times, we offer 100 percent service. In addition to the best diagnostics-capability and ease of repair, this includes availability of replacement parts 24/7 during the season. Furthermore, the Fendt Service network guarantees short paths between you and our trained Service staff. You also get a 12-month warranty on original Fendt parts and their installation. Repairs with original parts ensure that your Fendt tractor retains its value.

Individual financing and rental models

Purchasing machinery is a high capital investment. Your Fendt dealer will assist you in working out a customised financing plan for your new machine together with the agricultural financing experts at AGCO Finance. If you have a short-term need for additional capacity or prefer long-term use without having to buy, your Fendt sales partner has the ideal rental offer for you.



The best product, the best services: Certified Fendt dealers are distinguished by their first-class expertise and their comprehensive range of services. They regularly undergo strict audits to prove their high-quality of service. Your Fendt is in the best hands here.

With the smartphone app "AGCO Parts Books to Go", you can find and directly order Fendt replacement parts quickly and easily. The app is available through the App Store or the Google Play Store. Please contact your Fendt dealer for your personal access data.

LINKAGE AND HYDRAULICS

Flexible and powerful.



The rear linkage on the Fendt 200 Vario V/F/P

The Fendt 200 Vario V has a lift capacity of 2,775 daN, the F variant has 2,417 daN and the P variant 3,134 daN. The external controls on the rear left mudguard facilitate mounting implements. The rear lift on the Fendt 200 Vario V and F is designed as a swinging power lift, which has proven itself on steep slopes in particular.

Strong and adaptable: The front linkage

The front linkage on the Fendt 200 Vario V/F/P has a lift capacity of 2,380 daN. It can be conveniently operated directly with the multifunction joystick. The lower links fold up easily. An implement mounting plate is available when the lower links are removed completely. The front linkage on the Fendt 200 Vario P has a lift capacity of 2,540 daN. The lower links can be folded up and it is easy to operate using the multifunction joystick.



 The lower links can be adjusted to the right and left using two hydraulic cylinders. Swinging to both sides is possible in floating position. The rear implement is guided precisely in the row.

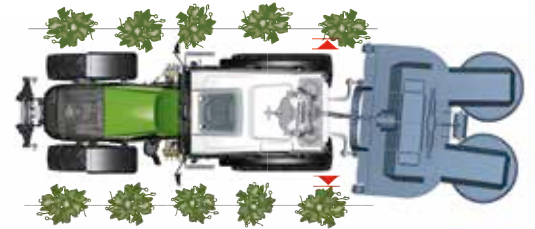

 The three-point linkage can be tilted in both directions with the two hydraulic cylinders. The rear-mounted implement can be guided precisely within the row on slopes.



Flexible hydraulic system

The dual-circuit hydraulics of the Fendt 200 V/F/P permit several implements to be operated at the same time with the proper oil pressure and oil flow for each. This guarantees economical operations at all times. The two hydraulic pumps supply several oil consumers, which are controlled with up to six valves in the centre and four connections at the rear. For combinations with an especially high oil requirement, one valve or the linkage can be prioritised.

Button assignment third and fourth circuit

The hydraulic functions for the third and fourth circuits can be operated on the joystick and the crossgate lever. Their functionality can be selected freely: on the one hand, the buttons can be assigned to switch on and off. On the other, the function can be performed as long as the button is pressed.

Top performance and still economical.



Stepless Vario transmission

For years now, the stepless Fendt Vario transmissions have proven their leading efficiency and performance and have become the first choice. Operators are always in the position to work at the optimal speed, which means considerable savings potential. You save valuable working time in different operations through higher area coverage and also profit from low fuel consumption.

Pedal mode

After the driving direction has been preselected with either the reverser lever or the joystick, all it takes to set the tractor in motion is to depress the pedal. In pedal mode, only the right foot is required to drive the tractor – similar to a car with an automatic transmission. The farther the pedal is pressed down, the faster the tractor goes.

Three-speed rear PTO

Power flows directly from the engine to the PTO stub, so the Fendt 200 Vario V/F/P is especially efficient in transmitting power to the PTO. With 540, 540 E and 1000, the tractor offers three PTO speeds for different types of work. A ground speed PTO is available as an option.

Rear PTO automatic

When the rear PTO automatic mode is enabled, the PTO is automatically switched on and off depending on the position of the rear linkage. When the PTO is actuated with the external controls on the rear mudguard, the preset engine speed is automatically activated. You can preselect which of these automated functions you would like to use in the multi-display.

EQUIPMENT VARIANTS

Fendt 200 Vario V/F/P.

Simply. Top notch.

	Fendt 200 Vario V/F/P	200V	200 F	200 P
Engine	Water-cooled turbo engine	■	■	■
	AGReX external exhaust gas recirculation	■	■	■
	Integrated air filter pre-cleaner	■	■	■
	Automatic cold-start	■	■	■
	Engine preheater	□	□	□
Transmission	TurboDutch function	■	■	■
	Cruise control	■	■	■
	TMS – Tractor Management System	□	□	□
	Automatic maximum output control 2.0	■	■	■
PTO	Rear 540/540E/1000 rpm	■	■	■
	Rear 540/ground/750 rpm	□	□	□
	Front 540 rpm or 1000 rpm	□	□	□
	PTO engagement control, electrohydr. preselection	■	■	■
	External controls for rear PTO	■	■	■
Chassis, driving safety	Front axle suspension self-levelling, lockable	□	□	□
	Shock load stabilising, electro-hydraulic linkage control	■	■	■
	Compressed air system			□
Linkage	Electrohydraulic linkage control EHR	■	■	■
	Swinging power lift	■	■	
	Mech. lateral and tilt control	■	■	
	Hydr. lateral and tilt adjustment with enhanced actuation	□	□	
	Quick coupler	■	■	■
	Steep lift	□	□	□
	Front linkage	□	□	□
Tilt control indicator, swinging power lift	□	□		
4WD/differential locks	Comfort controls 4WD/differential locks steering angle and speed-controlled	■	■	■
	Automatic front differential lock			■
	Rear and front differential with multi-disc locks	■	■	
	Fully protected cardan shaft	■	■	■
Hydraulics	Hydraulic tandem pump (max. 76 l/min) with hydraulic oil cooler	■	■	■
	Displacement pump (max. 106 l/min)	□	□	□
	2 electr. proportional valves – da flow controller floating position	■	■	■
	Up to 6 electr. proportional valves	□	□	□
	Crossgate lever	■	■	■
Impulse socket for external implement operation	■	■	■	

	Fendt 200 Vario V/F/P	200V	200 F	200 P
Operator environment	Safety frame	■		■
	Vario Joystick	■	■	■
	Height and tilt-adjustable steering column	■	■	■
	Self-cancelling flashers	■	■	■
	Additional lights, front (integral)	□	□	□
	Comfort seat with air suspension	■	■	■
	Comfort cab	□	■	□
	Profi equipment level: Multifunction joystick	□	□	□
	Hinged front / rear windows	■	■	■
	Roof window, hinged, with roller shade	■	■	■
	Hot water heater with 3-speed blower	■	■	■
	Integrated air conditioning	□	□	□
	Automatic climate control	□	□	□
	Activated carbon filters	□	□	□
Rear working lights	□	□	□	
Telescoping ext. rearview mirror	□	□	□	
Body	Low roof version	□	□	□
	Implement mounting plate	□	□	□
	Weights	□	□	□
	Socket for electr. speed signals	■	■	■
	Turn signal indicator front roof*	□		

* depends on the country's regulations

Technical Specifications.



Fendt 200 Vario V/F/P		207		208		209			210			211			
		V	F	V	F	V	F	P	V	F	P	V	F	P	
Engine	Rated speed (kW/DIN hp) ECER24	51/70	51/70	59/80	59/80	67/90	67/90	67/90	73/100	73/100	73/100	81/110	81/110	81/110	
	Rated power (kW/hp) EC 97/68	28/38	28/38	30/41	30/41	32/44	32/44	32/44	34/46	34/46	34/46	36/49	36/49	36/49	
	Maximum power (kW/hp) EC 97/68	55/75	55/75	63/85	63/85	70/95	70/95	70/95	77/105	77/105	77/105	85/115	85/115	85/115	
	No. of cylinders/cooling	3/water	3/water	3/water	3/water	3/water	3/water	3/water	3/water	3/water	3/water	3/water	3/water	3/water	
	Bore/stroke (mm)	108/120	108/120	108/120	108/120	108/120	108/120	108/120	108/120	108/120	108/120	108/120	108/120	108/120	
	Cubic capacity (cm ³)	3300	3300	3300	3300	3300	3300	3300	3300	3300	3300	3300	3300	3300	
	Rated engine speed (rpm)	2200	2200	2200	2200	2200	2200	2200	2200	2200	2200	2200	2200	2200	
	Opt. fuel consumption (g/kWh)	212	212	212	212	210	210	210	210	210	210	210	210	210	
	Max. torque Nm/rpm 1600 rpm	295	295	337	337	373	373	373	408	408	408	458	458	458	
	Torque rise (%)	35	35	32	32	30	30	30	30	30	30	44	44	44	
	Fuel tank capacity (l)	76	76	76	76	76	76	76	76	76	76	76	76	76	
	Transmission/PTO	Type	continuously variable Vario transmission												
		Speed range (forward / reverse)	0.02 to 40 km/h / 0.02 to 25 km/h												
Maximum speed 4WD (km/h) ²⁾		40	40	40	40	40	40	40	40	40	40	40	40	40	
Powershift rear PTO standard		540 / 540E / 1000													
Optional		540 / 540E / ground PTO ¹⁾													
Powershiftable front PTO ¹⁾	540 or 1000 ¹⁾														
Brakes	Rear brakes	wet ring piston brake													
	Four-wheel braking system for 4WD	Automatic 4WD engagement / hydraulic drum brake													
Electrical equipment	Battery (Ah)	50													
	Alternator	14 V / 120 A													
Weights and dimensions	Unladen weight with cab (kg)	2780	2860	2780	2860	2780	2860	3080	2780	2860	3080	2780	2860	3080	
	Unladen weight with safety bar (kg)	2580	—	2580	—	2580	—	2860	2580	—	2860	2580	—	2860	
	Max. perm. overall weight (kg)	4500	4500	4500	4500	4500	4500	5300	4500	4500	5300	4500	4500	5300	
	Max. hitch load (kg)	1500	1500	1500	1500	1500	1500	1500	1500	1500	1500	1500	1500	1500	
	Overall length (mm)	3578	3683	3578	3683	3578	3683	3701	3578	3683	3701	3578	3683	3701	
	Overall width narrow/wide (mm)	1070/1161	1340	1151/1269	1372	1151/1269	1372	1679	1269/1269	1372	1679	1305/1305	1372	1717	
	Wheelbase (mm)	2160	2160	2160	2160	2160	2160	2160	2160	2160	2160	2160	2160	2160	
	Overall height comfort cab (mm)	2360	2443	2390	2462	2390	2462	2486	2390	2462	2486	2390	2462	2488	
	Overall height low roof version (mm)	2210	2293	2240	2312	2240	2312	2336	2240	2312	2336	2240	2312	2338	
	Overall height safety frame (mm)	2383	—	2413	—	2413	—	2509	2413	—	2509	2413	—	2511	

1) Upon request 2) Speed depends on tyres

Contact to Fendt.

fendt.com

Here you will find everything online, from brochures to technical specifications, reports about customers or the company, up to the Fendt event calendar.

Fendt Configurator

With the Fendt Vehicle Configurator, you can choose from all the available equipment variations and put together the optimally equipped vehicle for your farm. The Fendt Configurator is available online at www.fendt.com, where you will find a quick link to it directly on the start page.

fendt.tv

Fendt around the clock – our Fendt Media Library makes it possible. Our internet TV provides you with news and information about Fendt 24/7.

facebook.com/FendtGlobal

Over 200,000 fans have already friended Fendt on Facebook. Come have a look.

Test drives

At fendt.com, you will find the area Service and Sales under "Fendt World". Select the "tractor demonstration service", then you can already register for a test drive with a tractor.

	Tyres		Min. track		Min. width
	Front	Rear	Front	Rear	Rear
207 V	7.5L15	280/85R24	794	777	1070
208 V	7.5R16	320/85R24	862	831	1155
209 V		12.4R24		831	1152
210 V		360/70R24		857	1202
211 V	280/60-15.5	420/65R20	946	887	1297
		400/70R20		927	1325
	10.0/75-15.3	320/70R24	844	831	1151
		12.4R24		831	1152
		360/70R24		857	1202
	11LR-16	380/70R24	948	897	1277
		440/65R24		957	1377
	265/70R16	12.4R24	852	831	1152
		320/70R24		831	1155
		400/60-26.5		957	1357
	280/70R16	320/85R24	852	831	1155
		12.4R24	831	831	1152
		340/80R24		857	1197
		360/70R24		857	1217
		420/65R24		957	1377
	320/65R16	380/70R24	948	897	1277
		440/65R24		957	1377

207 V	7.5L-15	280/85R24	894	831	1124
208 V	7.50R16	320/85R24	962	869	1193
209 V		12.4R24		869	1190
210 V		360/70R24		857	1202
211 V	280/60-15.5	420/65R20	1046	887	1297
	10.0/75-15.3	12.4R24	944	869	1193
		320/70R24		869	1190
	11LR-16	380/70R24	952	897	1277
		440/65R24		957	1377
	320/65R16	380/70R24	952	897	1277
		440/65R24		957	1377

	Tyres		Min. track		Min. width
	Front	Rear	Front	Rear	Rear
207 F – 211 F	280/70R18	12.4R28	1064	1000	1322
		14.9R24		1057	1459
		420/70R24		1088	1508
	280/80R18	13.6R28	1064	1000	1372
		380/70R28		1057	1447
		340/85R28		1000	1343
	11LR16	380/70R24	1048	1057	1497
		440/65R24		1057	1497
	320/65R16	380/70R24	1048	1057	1437
		440/65R24		1057	1497
	320/65R18	420/70R24	1064	1088	1508
		12.4R28		1057	1477
	340/65R18	13.6R28	1064	1000	1372
		340/85R28		1057	1447
	340/85R28		1000	1343	
	440/65R28		1057	1477	
209 P – 211 P	280/80R18	380/85R28	1212	1288	1668
		14.9R28		1188	1598
		420/70R28		1288	1703
	280/70R20	420/70R28	1212	1288	1703
		380/85R28		1288	1668
		14.9R28		1188	1598
		480/65R28		1288	1739
	11LR16	14.9R24	1235	1288	1696
		420/70R24		1288	1703
	340/65R18	14.9R28	1352	1788	1598
	380/85R28		1288	1679	
	420/70R28		1288	1708	
	480/65R28		1288	1739	

Note:

Standard equipment

Optional

What can we do for you?

What makes Fendt Service different?

For us, service means knowing and understanding your work in order to meet your demands for reliability and safety and to act in your economic interest. We stand behind our products and have developed them for the highest demands and long-term operation. Our service is the partnership aspect for your work.

What is Fendt Expert?

Become a Vario pro with Fendt Expert driver training: Are you already familiar with all the functions that the technology has to offer? Take advantage of the technology that is found in every Fendt Vario and learn how to optimise the use of all the features with Fendt Expert. Our team of professional instructors offers you competent instruction to enable you to exploit the full performance potential of your Fendt tractor. Inform yourself through your dealer and sign up.



**FENDT SPOTLIGHT.
NOTABLE. BETTER.**

This symbol stands for solutions that offer special benefits for your daily work and make a Fendt a Fendt.

FENDT

Leaders drive Fendt.



www.fendt.com

AGCO GmbH – Fendt Marketing
87616 Marktobendorf, Germany

 **AGCO**
Your Agriculture Company

Fendt is a worldwide brand of AGCO.
All data regarding delivery, appearance, performance, dimensions and weight, fuel consumption and running costs of the vehicles correspond with the latest information available at the time of going to press. Changes may be made before the time of purchase. Your Fendt dealer will be pleased to supply you with up-to-date information. The vehicles are not shown with country-specific equipment.